

FCAD

EDDC

Equipment Distribution
Centre

MICROPHONE GUIDEBOOK

**Andy Kufluk Equipment Distribution Centre
80 Gould St. Room RCC-166
Toronto, ON
(416) 979-5000 ext.7534**

**Ryerson
University**

**Faculty of
Communication
& Design**

Summer 2019
Liam Brand

AUDIO TECHNICA U851A



TYPE Condenser Boundary

PICKUP Half Cardioid

POWER Battery or 48v

COMMON USES Conferencing, Interviews, Piano

SIMILAR MICS PCC-130, PMD661

Frequency Response:

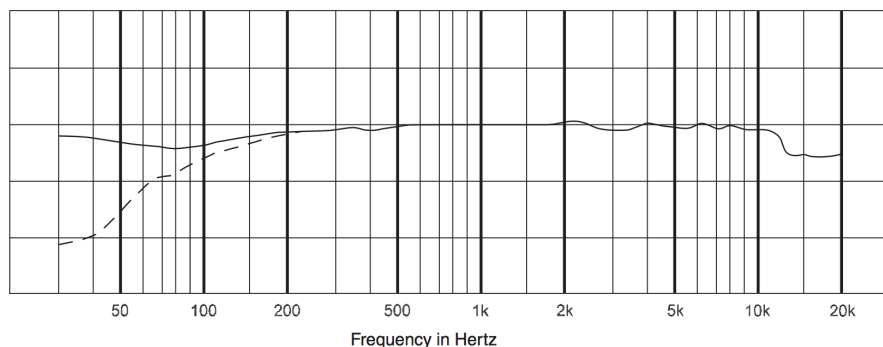

LEGEND ——— 12" or more on axis
- - - - - Roll-off

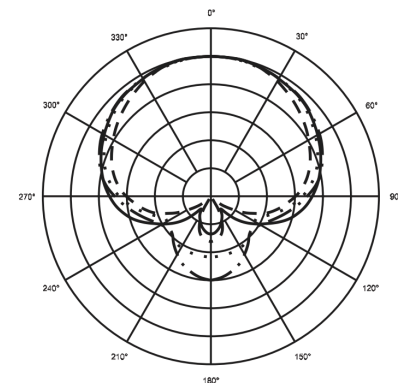

LEGEND
200 Hz ———
1 kHz ———
5 kHz ·····
8 kHz - - - - -

SCALE IS 5 DECIBELS PER DIVISION

Notes:

- High-quality, multi-use boundary mic
- Simple way to record a conversation or interview without a mic stand
- Mount inside piano in studio or on stage for a great close-mic sound
- Resistant against feedback in live situations

AKG CROWN PCC-130



TYPE Condenser Boundary

PICKUP Tilted Cardioid

POWER 48v

COMMON USES Interviews, Lectures, Podcasting

SIMILAR MICS AT U851A, PMD661

Frequency Response:

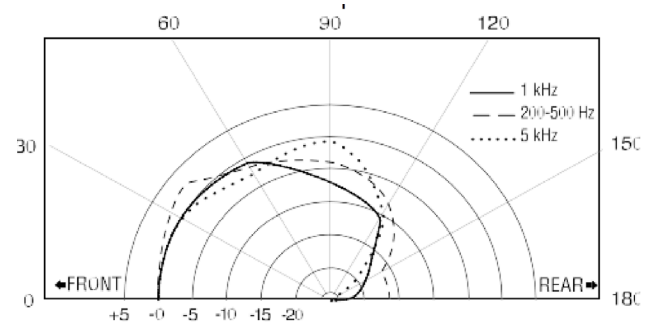
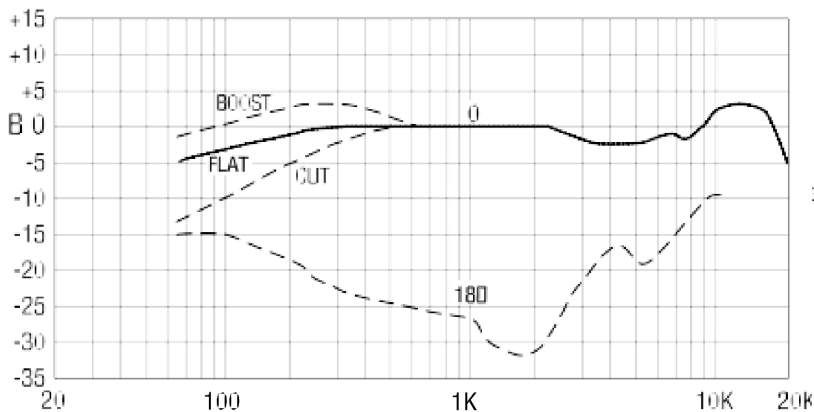

Notes:

- PCC® (Phase Coherent Cardioid®) technology boosts speech intelligibility
- Easy and discreet setup for recording conversation without a mic stand
- It's fairly directional, so better for recording a single sound source rather than several

CAD U7



TYPE USB Boundary Mic

PICKUP Omnidirectional

POWER USB

COMMON USES Meetings, Interviews, Presentation

SIMILAR MICS Blue Snowball

MXL uCHAT AC-406

TYPE USB Boundary Mic

PICKUP Half Cardioid

POWER USB

COMMON USES VOIP Calling, Web Conferencing

SIMILAR MICS CAD U7



Notes:

- Has both a built-in microphone AND speaker for all-in-one conferencing capabilities

SENNHEISER MD 46



TYPE Handheld Dynamic

PICKUP Cardioid

POWER None

COMMON USES Reporting, Interview, Field Production

SIMILAR MICS EV RE50N

Frequency Response:

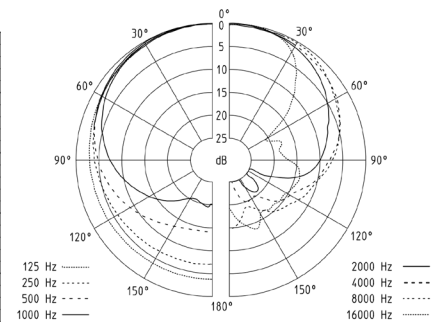
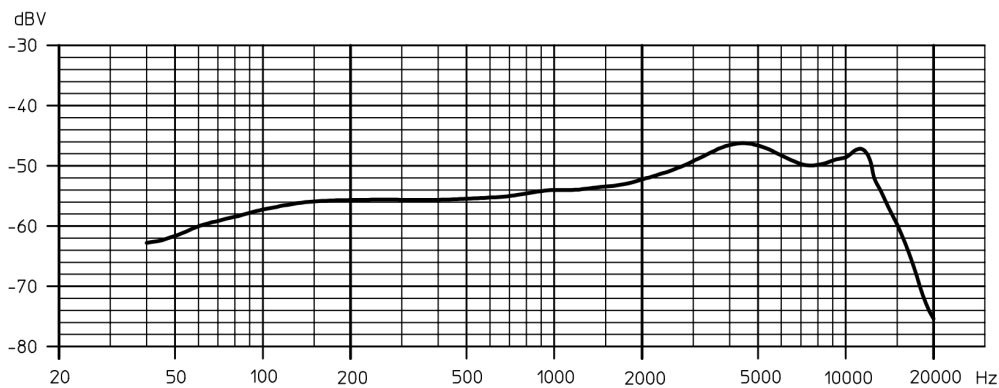

Notes:

- Optimized frequency response enhances speech clarity
- Whereas omnidirectional microphones pick up all sound equally, including background noise, the MD 46 only focuses on where it's being pointed and blocks out everything else

ELECTRO VOICE RE50N/D-B



TYPE Handheld Dynamic

PICKUP Omnidirectional

POWER None

COMMON USES Interview, News Gathering, Field Production

SIMILAR MICS MD 46, EV 635A

Frequency Response:

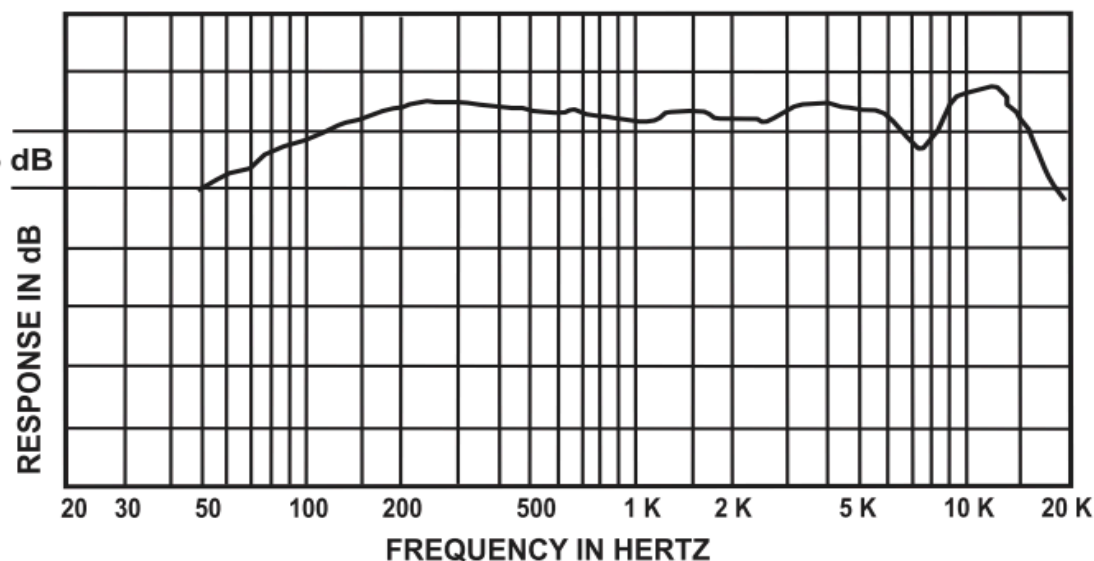

Notes:

- 4 stage pop filter effectively blocks out most pops and plosives
- Omnidirectional: picks up sounds equally from all directions
- Very low handling noise

Sony F-112



TYPE **Handheld Dynamic**

PICKUP **Omnidirectional**

POWER **None**

COMMON USES **Interview, News Gathering, Field Production**

SIMILAR MICS **RE50N, EV635A**

Frequency Response:

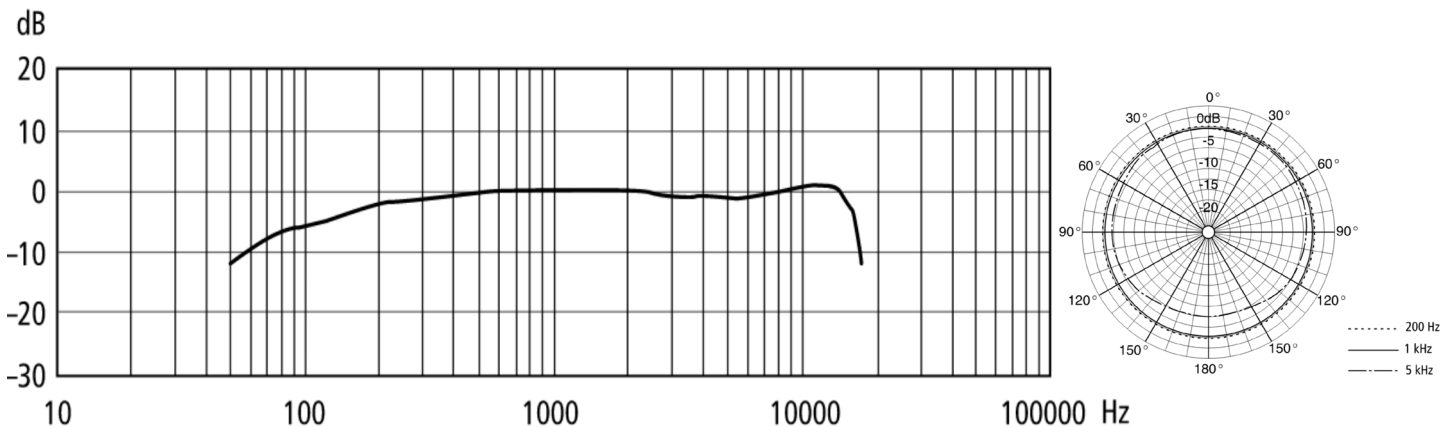

Notes:

- High sensitivity, great for pickup up voices at varying distances and all directions
- Smooth and natural sound reproduction
- Omnidirectional: picks up sounds equally from all directions

ELECTROVOICE EV635A



TYPE Handheld Dynamic

PICKUP Omnidirectional

POWER None

COMMON USES Interview, Reporting, Electric Guitar, Vocals

SIMILAR MICS RE50N, MD 46

Frequency Response:

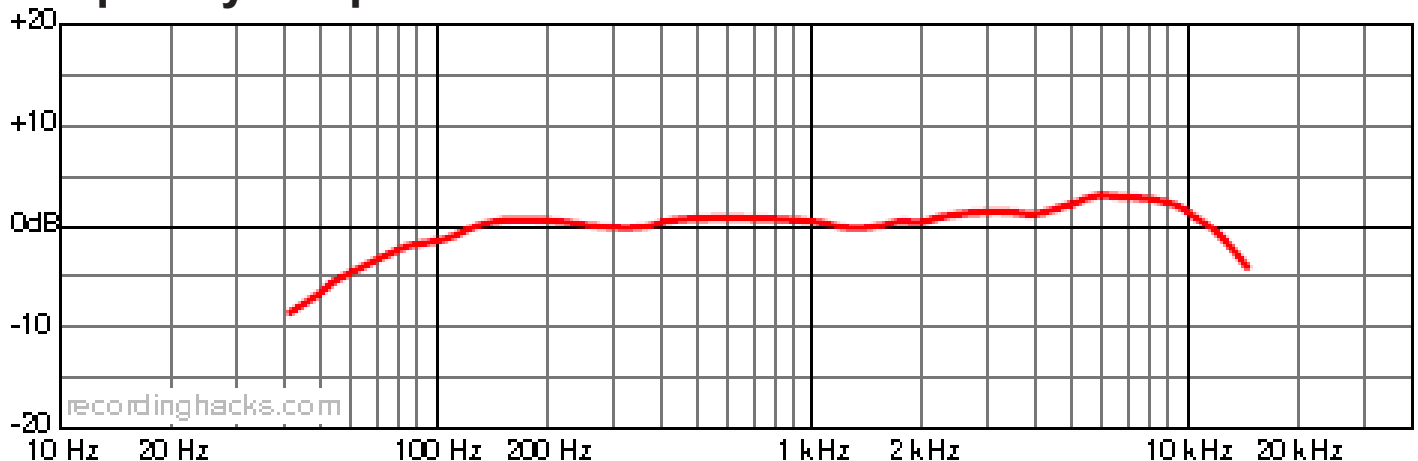

Notes:

- “The best-known news gathering mic in the world”
- Very versatile. Primarily used for journalism but is an effective and unique-sounding mic in music recording.
- The built-in 4 stage pop filter ensures minimal plosives
- Durable design makes it ideal for field recording

AUDIO-TECHNICA AT8004



TYPE	Handheld Dynamic
PICKUP	Omnidirectional
POWER	None
COMMON USES	Interview, News Gathering, Ambience
SIMILAR MICS	RE50N, EV635A

Frequency Response:

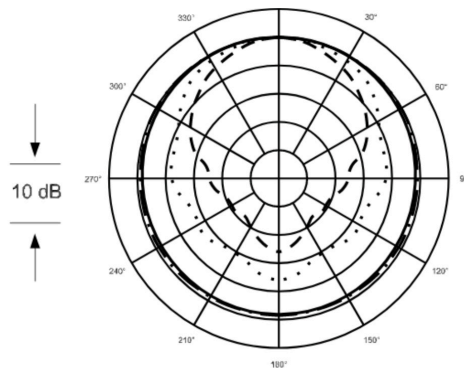
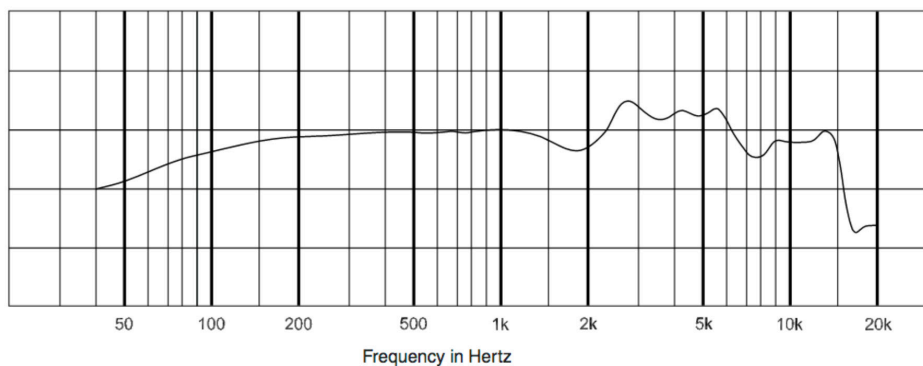

LEGEND ——— 12" or more on axis

LEGEND
200 Hz — · · · · ·
1 kHz — — — — —
5 kHz — · · · · ·
8 kHz — - - - - -

Notes:

- Sounds great for interviews, and is significantly more discreet and lightweight than the MD46
- Internal shock mount to reduce handling noise
- Omnidirectional: picks up sounds equally from all directions

SHURE SM58



TYPE Handheld Dynamic

PICKUP Cardioid

POWER None

COMMON USES Live Vocals

SIMILAR MICS SM57, TG-X 48

Frequency Response:

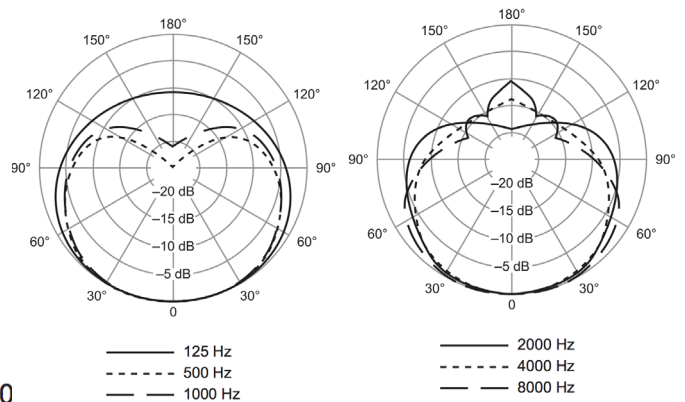
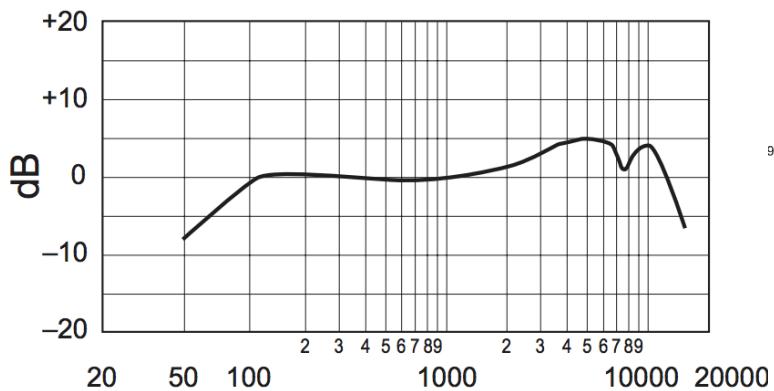

Notes:

- By far the most common mic you will see used for live vocals
- Very close pickup pattern and strong off-axis rejection
- Very durable

Beyerdynamic TG-X 48



TYPE **Handheld Dynamic**

PICKUP **Super Cardioid**

POWER **None**

COMMON USES **Live Vocals**

SIMILAR MICS **SM58**

Frequency Response:

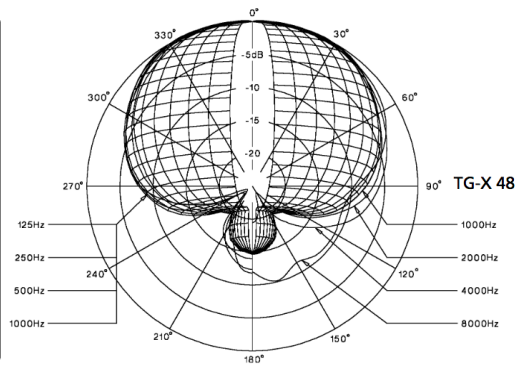
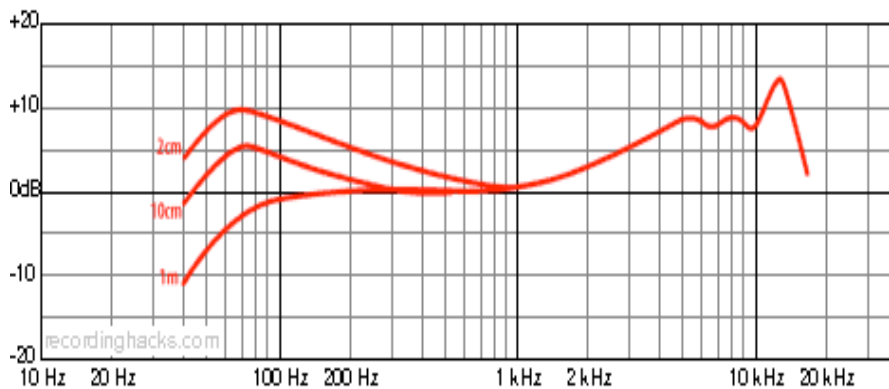

Notes:

- Modelled after the SM58, with the intention of being a higher quality alternative
- Improved built-in wind screen
- Smoother sound, with a tighter off-axis rejection
- “Special soft finish” to make for a more comfortable grip

SHURE SM57



TYPE Dynamic

PICKUP Cardioid

POWER None

COMMON USES Snare, Elec. Guitar, Cymbals

SIMILAR MICS SM58

Frequency Response:

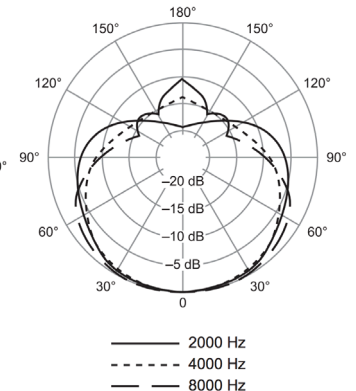
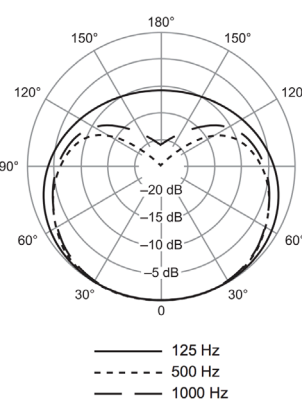
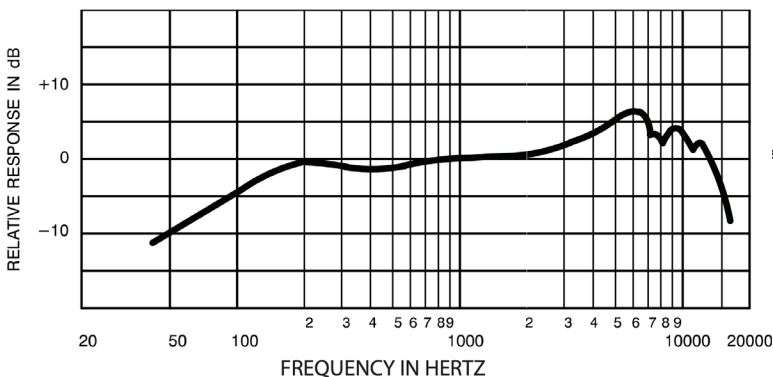

Notes:

- The famous industry standard go-to instrument dynamic mic
- Most snare and electric guitar recordings you have heard were probably recorded using an SM57
- Same microphone capsule as the SM58, but a modified grill for close miking

SHURE BETA 52A



TYPE Dynamic Kick Drum Mic

PICKUP Supercardioid

POWER None

COMMON USES Kick Drum, Bass

SIMILAR MICS AKG D112, RE20

Frequency Response:

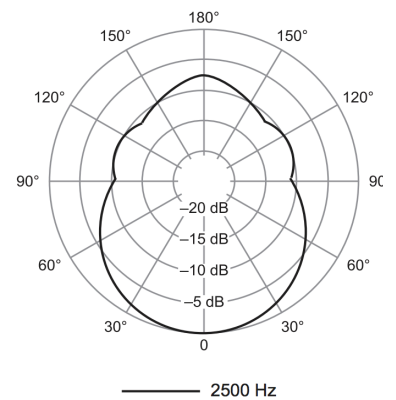
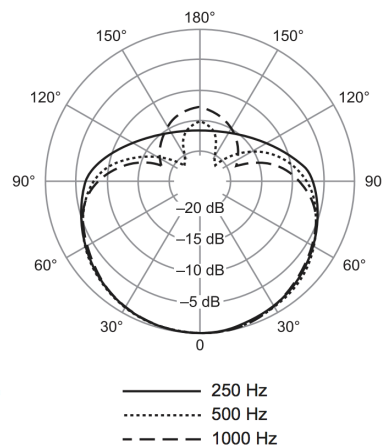
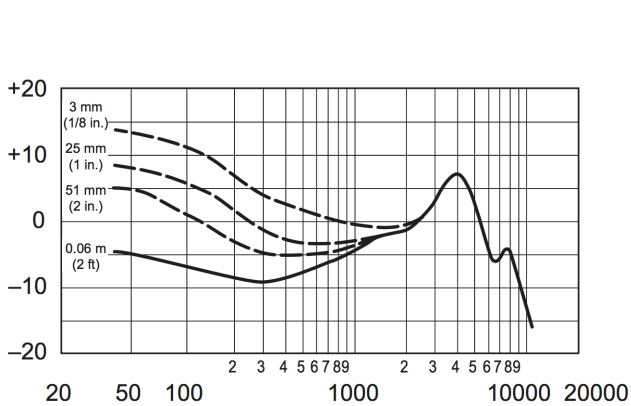

Notes:

- **ONLY AVAILABLE IN SHURE DRUM MIC KIT**
- Very little bleed makes it great for both live and studio use
- Joe Barresi's favorite kick mic (Nine Inch Nails, Weezer, Kelly Clarkson, Every Time I Die)

AKG D112



TYPE Dynamic Kick Drum Mic

PICKUP Cardioid

POWER None

COMMON USES Kick Drum, Bass, Floor Tom

SIMILAR MICS BETA 52A, RE20

Frequency Response:

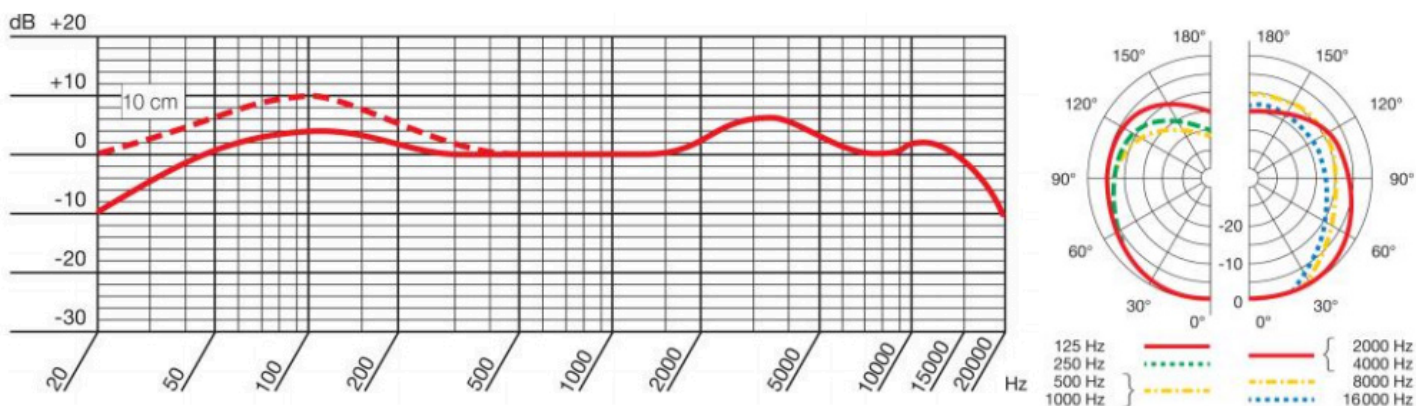

Notes:

- One of the most popular kick mics in the industry
- Modelled after the classic D12 (the world's first dynamic cardioid microphone)
- Endorsed by producers such as Steve Albini (Nirvana), Steve Churchyard (Joni Mitchell), Bob Clearmountain (Bruce Springsteen), and Steven Street (The Smiths)

AKG D200E



TYPE Two Way Dynamic

PICKUP Cardioid

POWER None

COMMON USES Drums, Electric Guitar, Piano

SIMILAR MICS SM57, D202E

Frequency Response:

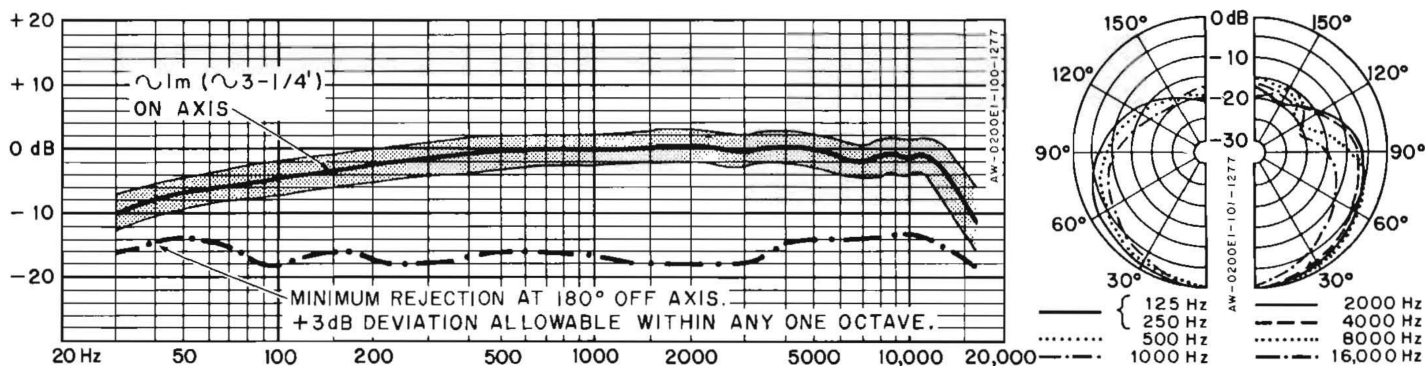

Notes:

- Bright, vintage sound
- Good for experimenting. Try it on anything!
- Unique two-way capsule design means it can get as close to a sound source as possible without exhibiting proximity effect

AKG D202E



TYPE Two Way Dynamic

PICKUP Cardioid

POWER None

COMMON USES Snare, Toms, Vocals

SIMILAR MICS D200E, D224E

Frequency Response:

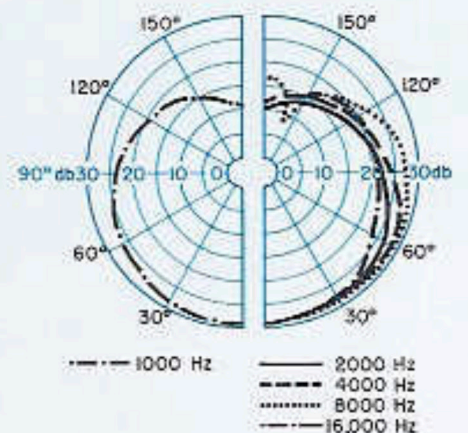
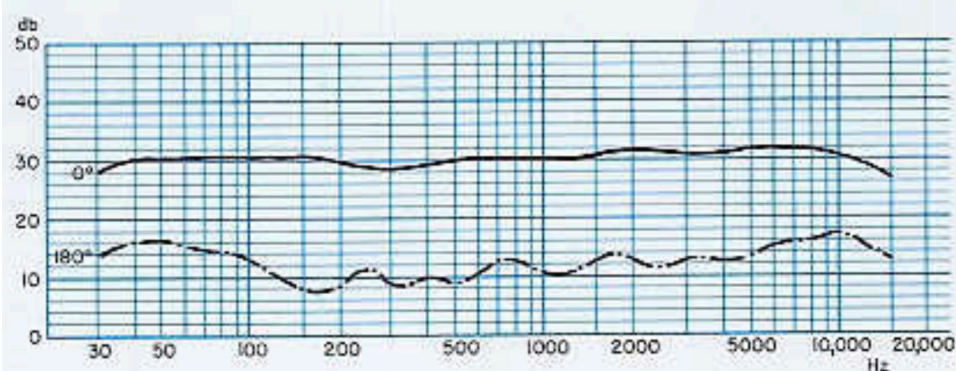

Notes:

- Dual capsule design, sounds like a condenser with the SPL capabilities of a dynamic
- Vintage sound with a wide frequency range (30hz-18khz)
- Popular in 70s heavy rock recording

AKG D224E



TYPE Two Way Dynamic

PICKUP Cardioid

POWER None

COMMON USES Electric Guitar, Acoustic Guitar, Snare

SIMILAR MICS D200E, D202E

Frequency Response:

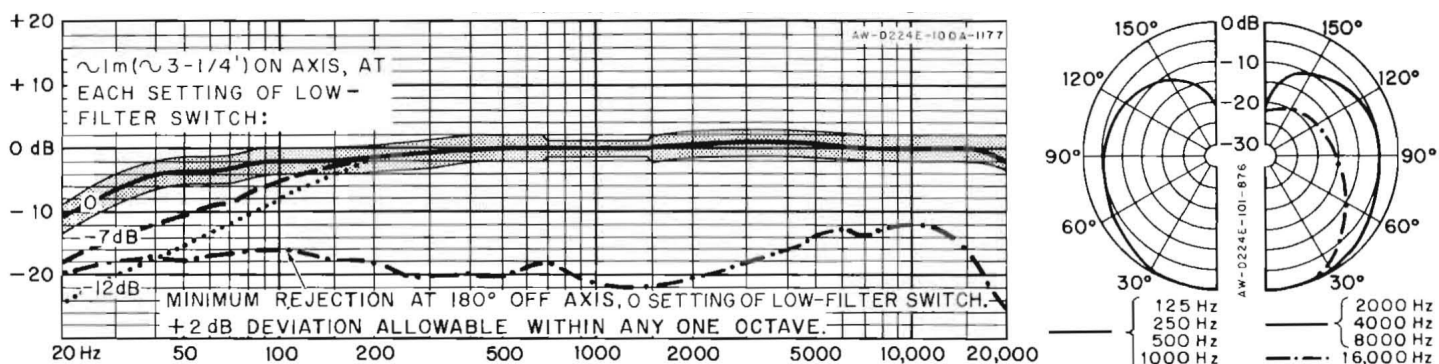

Notes:

- Widest frequency range in the product series (20hz-20khz)
- Very detailed sound with great off-axis rejection
- Sounds great on practically anything

ELECTROVOICE RE20



TYPE Dynamic

PICKUP Cardioid

POWER None

COMMON USES Vocals, Bass, Kick Drum, Broadcast

SIMILAR MICS SM7B, 421, PR 40

Frequency Response:

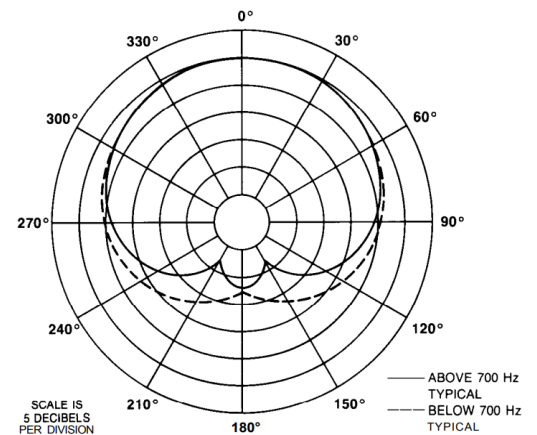
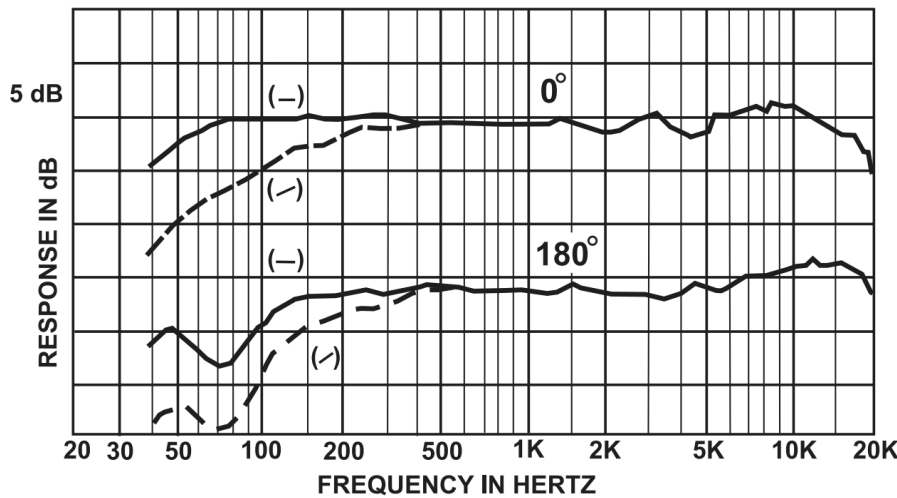

Notes:

- Frequently used as a vocal mic by Thom Yorke of Radiohead both live and in studio
- Unique body design and capsule placement make it immune to proximity effect. Get as close as you need without colouring the sound

HEIL SOUND PR 30



TYPE Dynamic

PICKUP Cardioid

POWER None

COMMON USES Drums, Electric Guitar, Loud Vocals

SIMILAR MICS PR 40, SM57

Frequency Response:

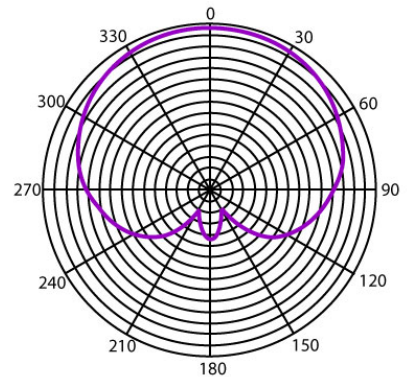
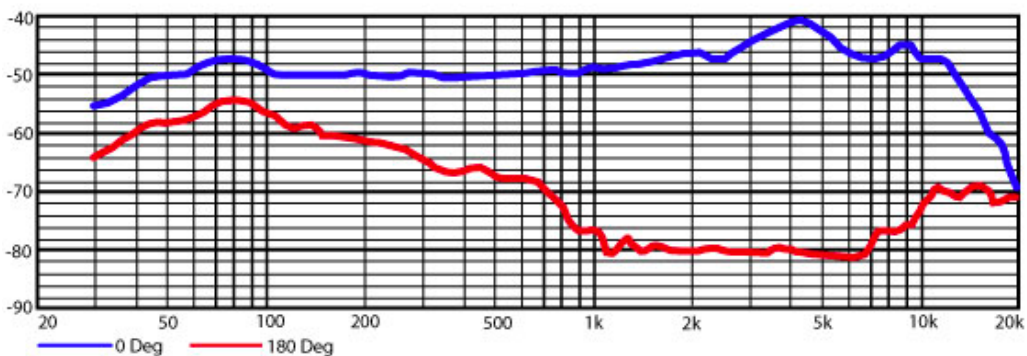

Notes:

- **End-Fire/Top-Adress**
- Kurt Ballou's (Converge, Code Orange) favored mic for electric guitar, snare, and bass
- Sounds like a ribbon mic, but able to handle extreme SPLs

HEIL SOUND PR 40



TYPE Dynamic

PICKUP Cardioid

POWER None

COMMON USES Kick Drum, Bass, Podcast

SIMILAR MICS SM7B, RE20, MD 421

Frequency Response:

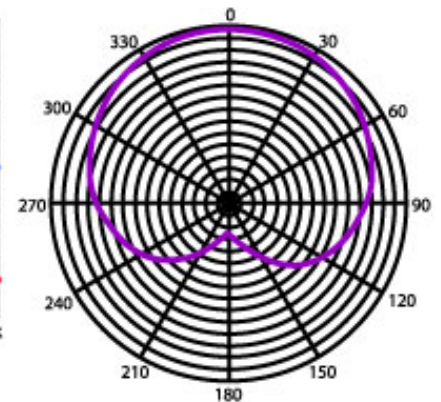
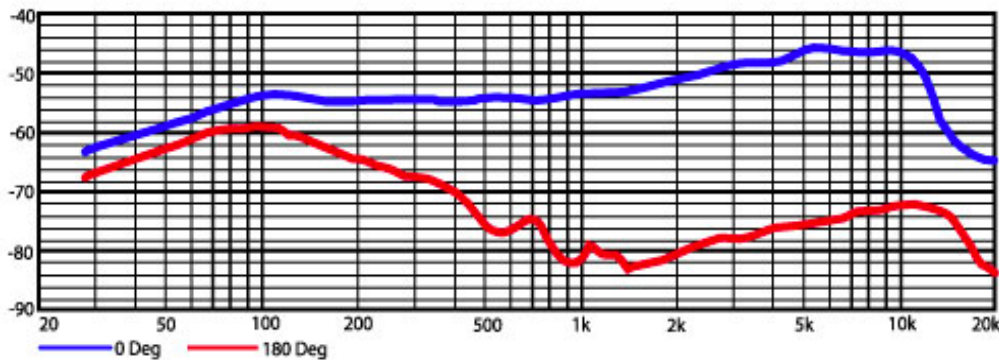

Notes:

- **End-Fire/Top-Address**
- These are the mics we have in the Alan Slaight
- Great low-end response, sounds like a beefier SM7B
- Use it for your podcast to bring out that deep “radio host” richness in your voice

SHURE SM7B



TYPE Dynamic

PICKUP Cardioid

POWER None

COMMON USES Vocals, Podcast, Electric Guitar, Bass, Horns

SIMILAR MICS PR 40, MD 421

Frequency Response:

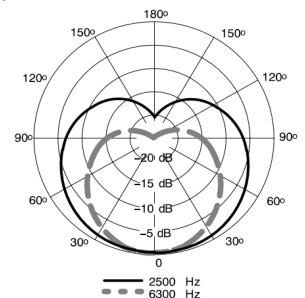
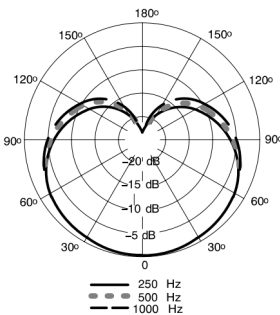
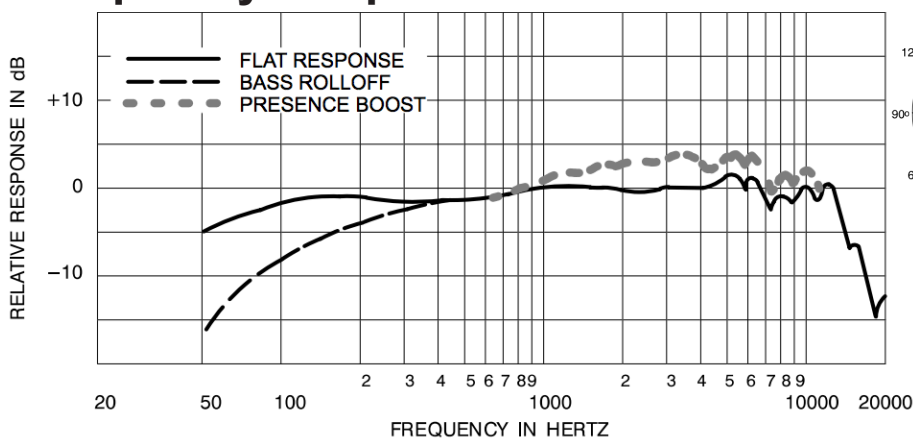

Notes:

- Useful for close-miking instruments in studio where warm and smooth full-frequencies are a must
- Improved version of classic vocal mic used by Michael Jackson and Bob Dylan, still a go-to for contemporary acts such as Brockhampton
- Popular pod/broadcast microphone

AKG C414B XLII



TYPE	Capacitor Condenser
PICKUP	Omni, Figure 8, Cardioid, Wide Card, Super Card.
POWER	48v
COMMON USES	Vocals, Kick Drum, Acoustic Gtr, Piano, Foley
SIMILAR MICS	AT 4050, NT2

Frequency Response: *Omnidirectional*

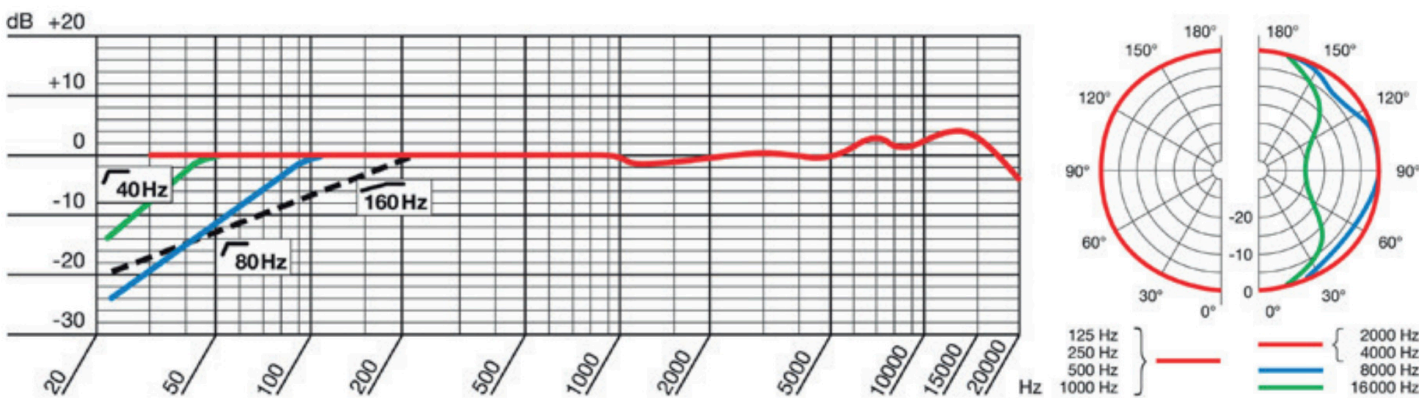
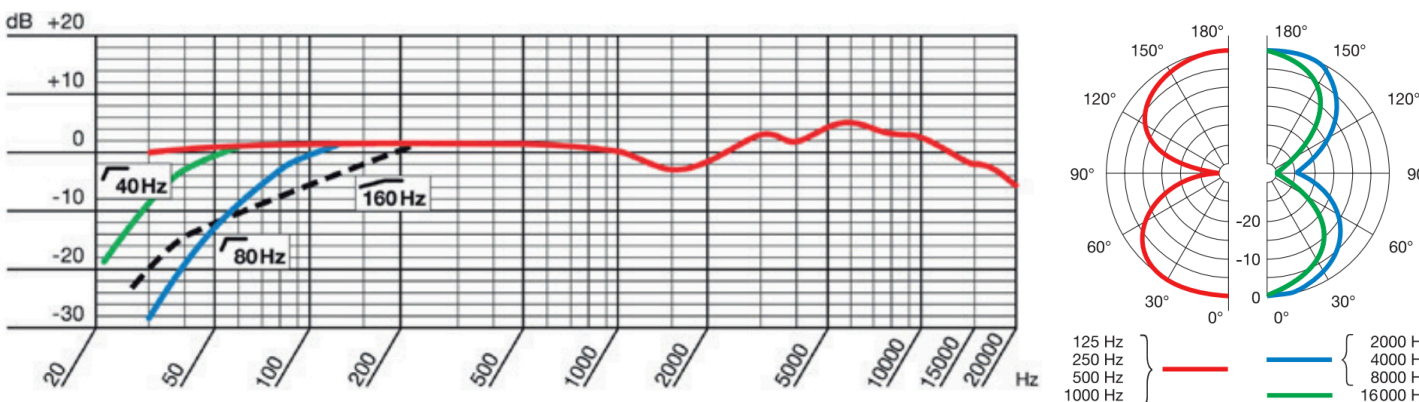
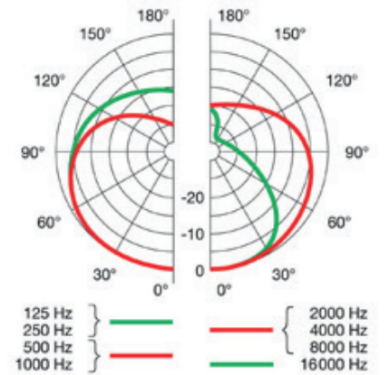
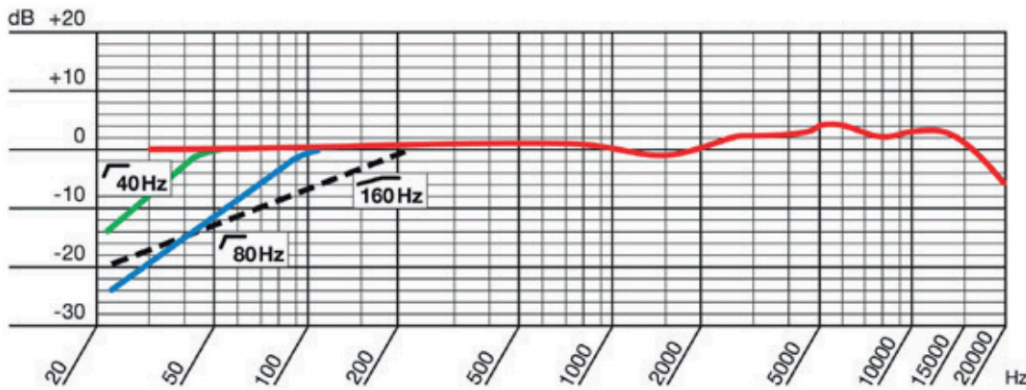

Figure 8



AKG C414B XLII cont.

Cardioid



Wide Cardioid

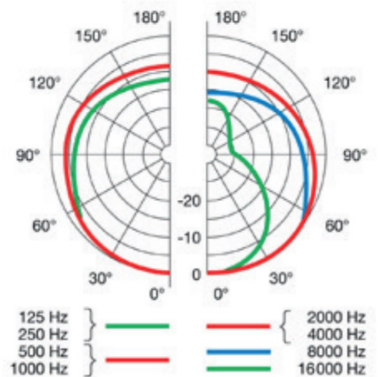
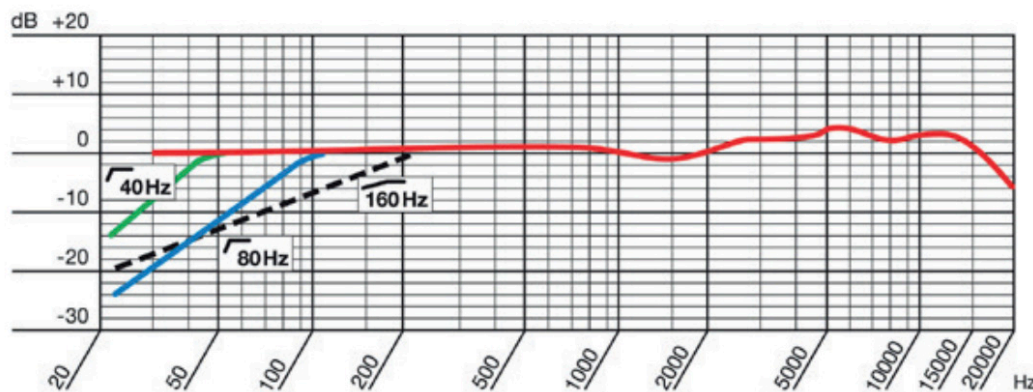

Hypercardioid

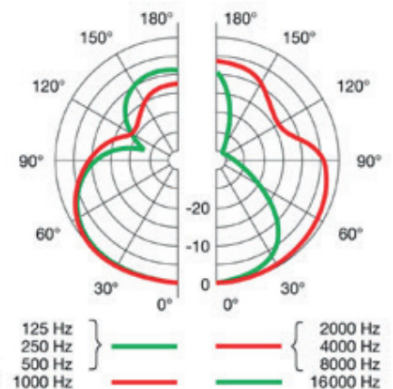
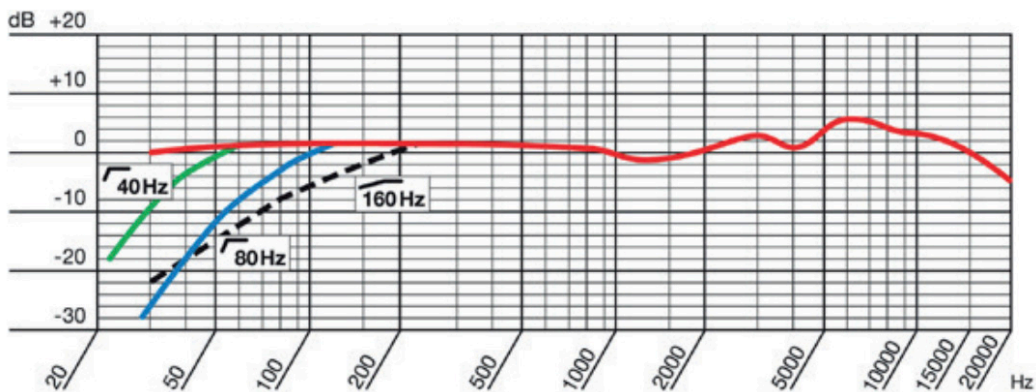

Notes:

- Very versatile, worth trying on anything and everything
- Point side with 'AKG' logo at sound source

AKG C3000



TYPE Dual Capsule Large Diaphragm Condenser

PICKUP Cardioid, Super Cardioid

POWER 48v

COMMON USES Vocals, Electric/Acoustic Guitar, Drum Room

SIMILAR MICS C414, NT2, MXL 770

Frequency Response:

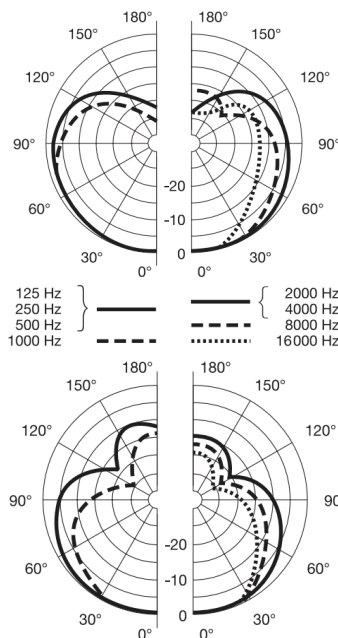
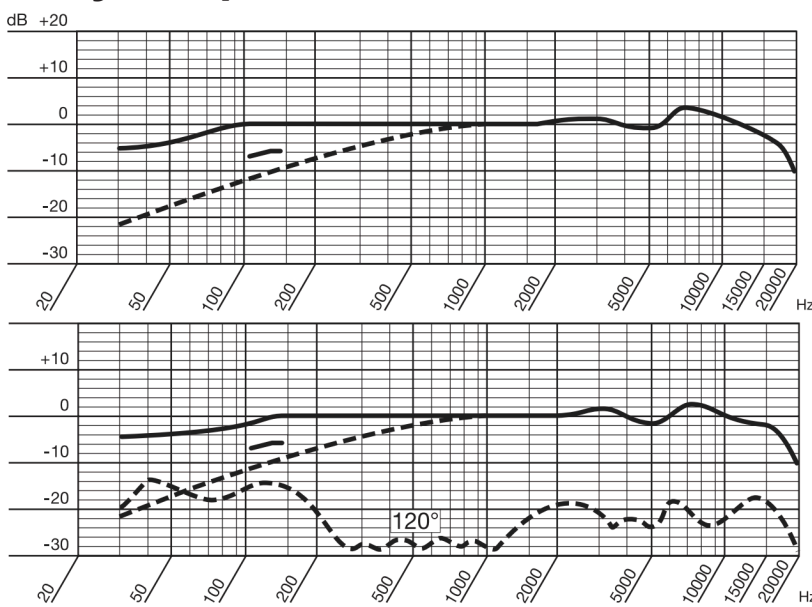

Notes:

- Created as an affordable alternative to the C414, similar capsule/sound
- “Classic AKG vocal mic sound”
- Feedback-resistant and low handling noise makes it great for live use

APEX 420



TYPE Large Diaphragm Condenser

PICKUP Omnidirectional, Cardioid

POWER 48v

COMMON USES Vocals, Drum Room, Acoustic Guitar

SIMILAR MICS NT2, MXL 770

Frequency Response:

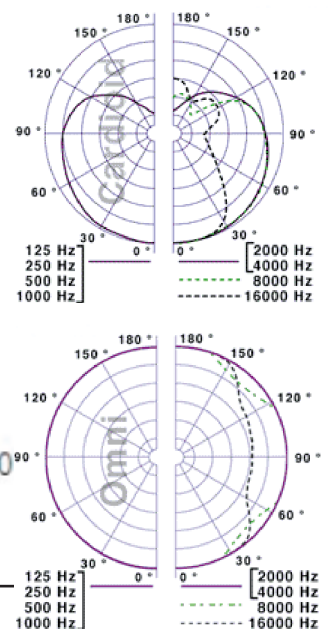
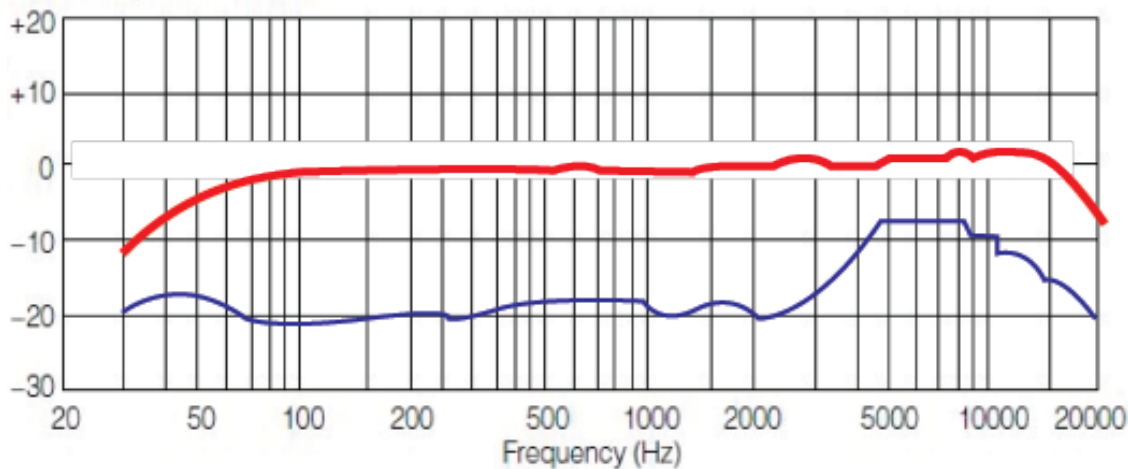

Notes:

- Features a low end roll off switch (-6db below 100hz)
- Can handle up to 130dB SPL without distortion
- The front of the mic is the side with the switches

AUDIO TECHNICA AT4050



TYPE Large Diaphragm Condenser

PICKUP Cardioid, Omni, Figure 8

POWER 48v

COMMON USES Acoustic Guitar, VO, Kick, Room, Overhead

SIMILAR MICS C414, NT2A

Frequency Response:

Cardioid

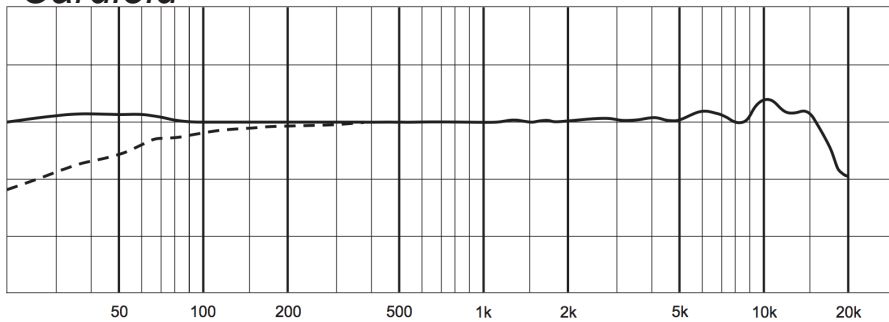

10 dB

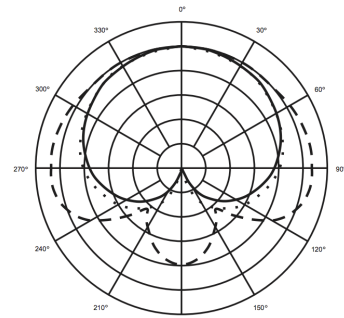

Omnidirectional

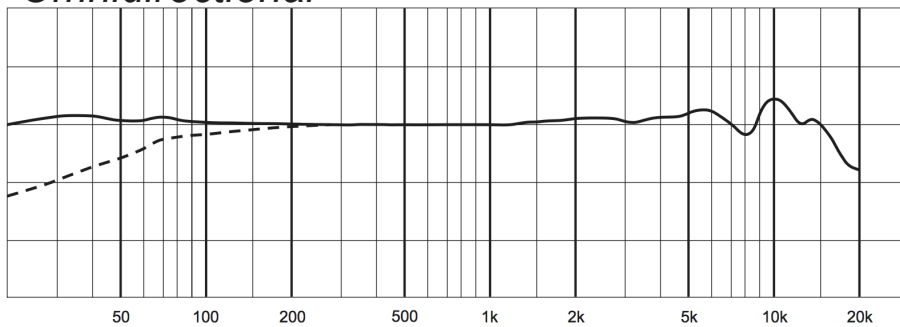

10 dB

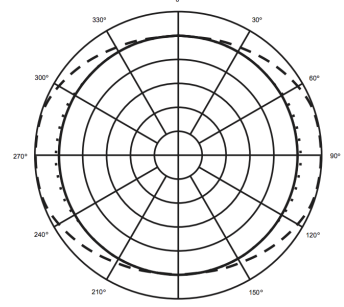

SCALE IS 5 DECIBELS PER DIVISION

LEGEND

200 Hz — same as 1 kHz
 1 kHz — — — — —
 5 kHz - - - - -
 8 kHz - - - - -

Bidirectional

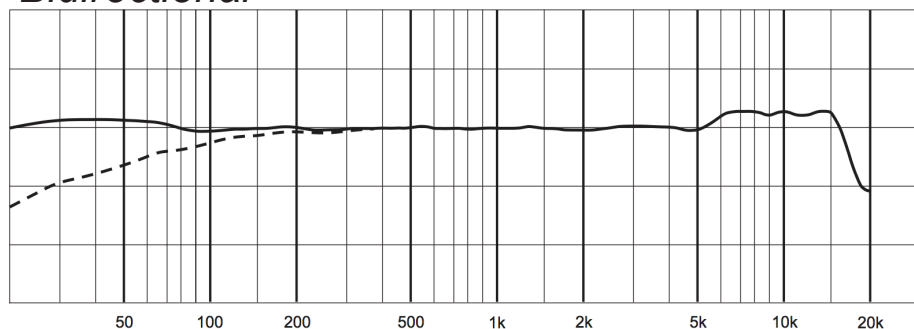

10 dB

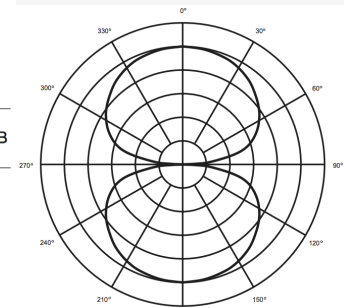

BLUE BABY BOTTLE



TYPE Large Diaphragm Condenser

PICKUP Small Cardioid

POWER 48v

COMMON USES Vocals/VO, Drums, Acoustic Guitar, Brass

SIMILAR MICS TLM 103, C414

Frequency Response:

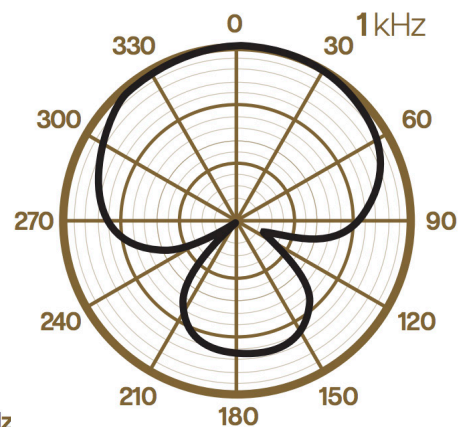
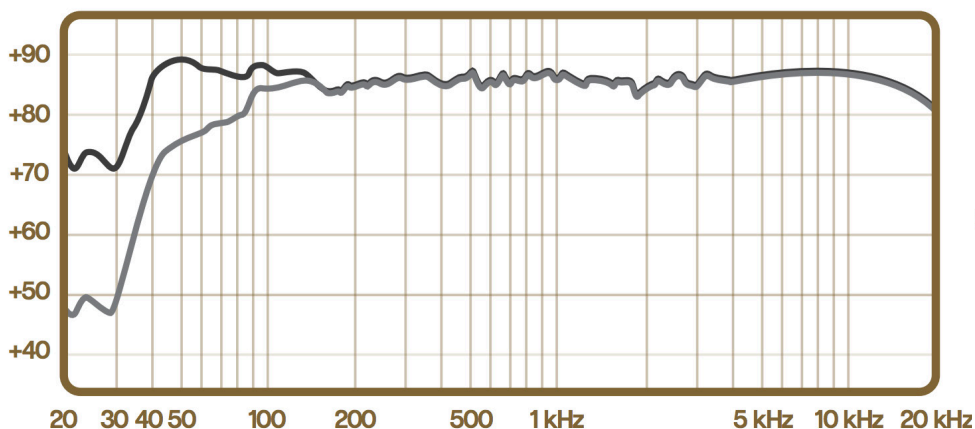

Notes:

- High output and low noise, reproduces a clean sound that can be heavily manipulated/affected and still sound nice
- Very crisp, high-presence sound
- Unique sonic characteristics, great to use for experimentation

KEL HM-7U



TYPE Large Diaphragm Condenser

PICKUP Super Cardioid

POWER 48v

COMMON USES Vocals, Voiceover, Kick

SIMILAR MICS TLM 49

Frequency Response:

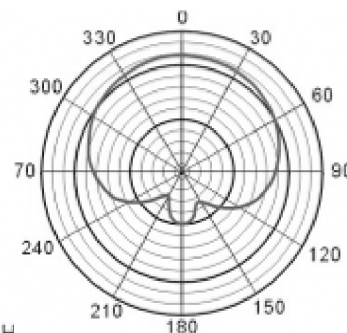
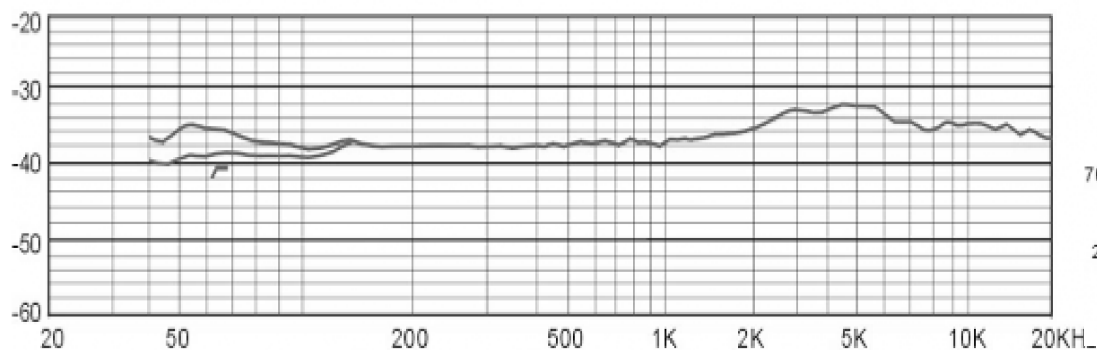

Notes:

- Designed as a clone of the historic U47 (Vocal mic used by the Beatles, Sinatra, etc)
- Front of mic is the side with the glowing light

MXL 770



TYPE Large Diaphragm Condenser

PICKUP Small Cardioid

POWER 48v

COMMON USES Vocals, Piano, Strings, Cymbals

SIMILAR MICS NT1, C3000

Frequency Response:

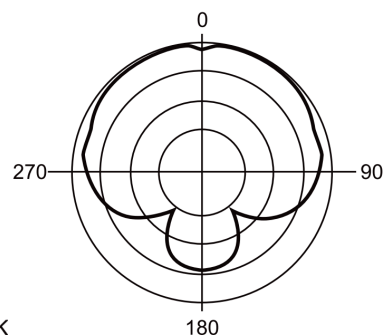
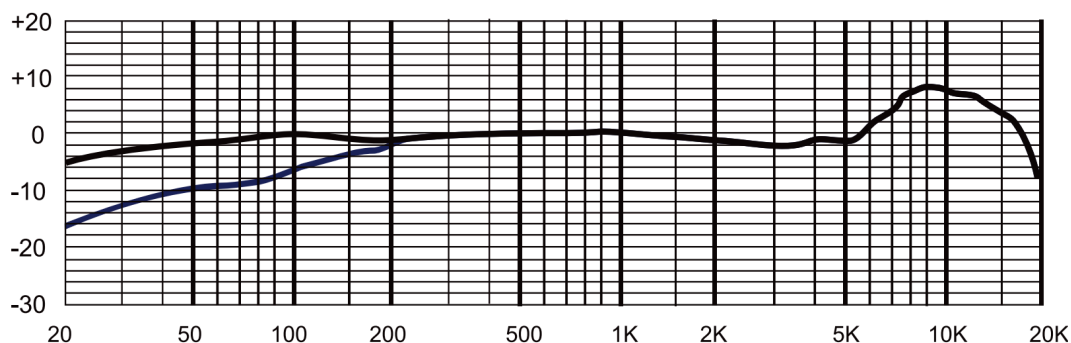

Notes:

- Multipurpose condenser with a bright sound
- Particularly suited for rap vocals because of the solid bass response and bright top end
- Bass roll-off and -10db pad switches
- Front of mic is the side with the 'MXL' logo

NEUMANN TLM 103



TYPE Large Diaphragm Condenser

PICKUP Cardioid

POWER 48v

COMMON USES Vocals, VO, Drum Room, Strings, Sound Design

SIMILAR MICS Baby Bottle, C414

Frequency Response:

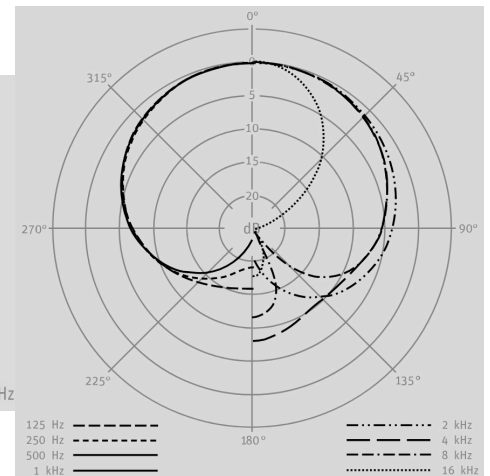
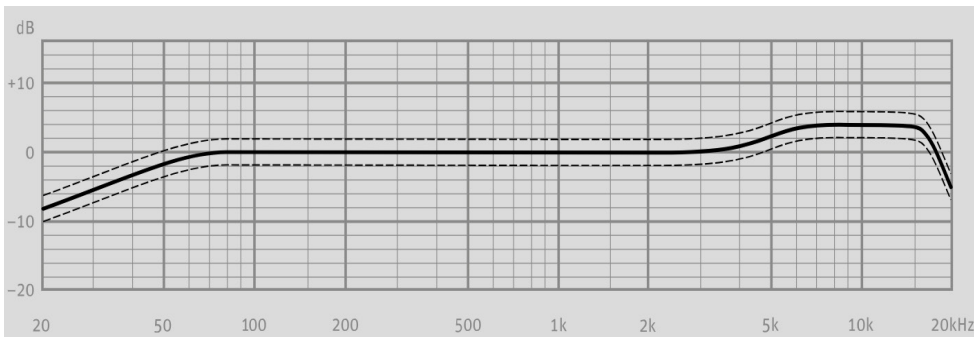

Notes:

- A faithful modernized version of the Neumann U87 (“The world’s most famous vocal mic”, used by artists such as The Beatles, Ray Charles, Amy Winehouse, Stevie Wonder, and Beyonce)
- Extremely low noise means dramatic EQ or compression can be applied and still sound good
- Front of mic is the side with the Neumann logo

NEUMANN TLM 49



TYPE Large Diaphragm Condenser

PICKUP Cardioid

POWER 48v

COMMON USES Vocals, VO, Acoustic Guitar, Bass, Foley

SIMILAR MICS KEL HM-7U

Frequency Response:

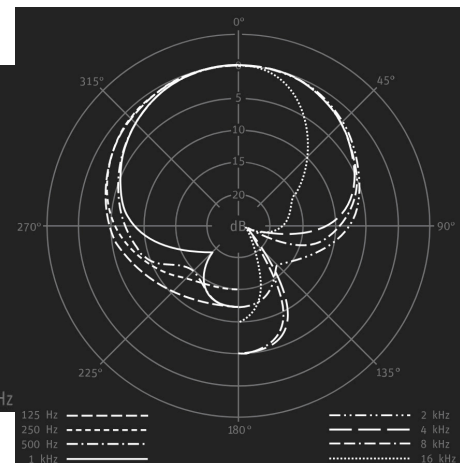
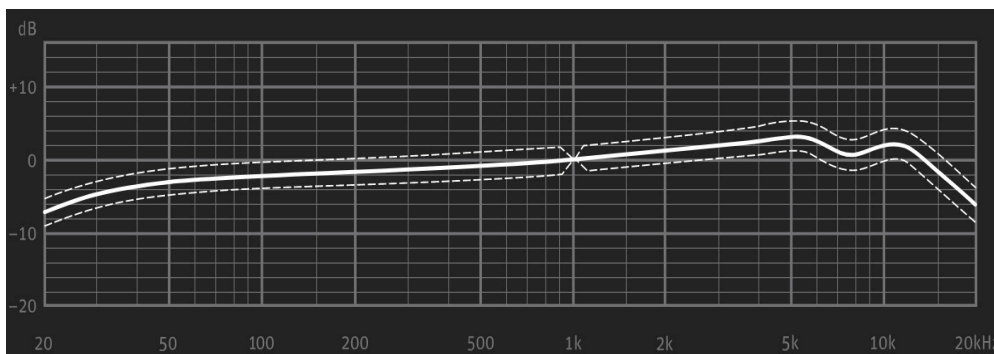

Notes:

- Emulates the smooth, vintage tube sound of the U47 (Frank Sinatra, The Beatles, Adele) and M49 (1950s jazz standard microphone)
- Large, open headgrille gives vocals a very spacious sound
- Front of mic is the side with the Neumann logo

RODE NT2000



TYPE Large Diaphragm Condenser

PICKUP Cardioid, Omni, Figure 8

POWER 48v

COMMON USES Vocal, Any instrument

SIMILAR MICS NT2A

Frequency Response:

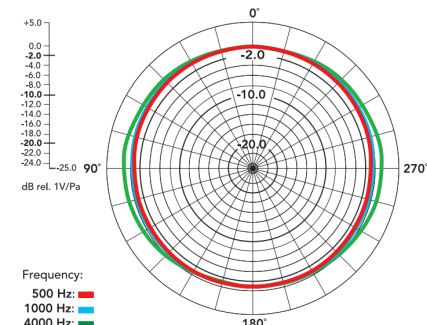
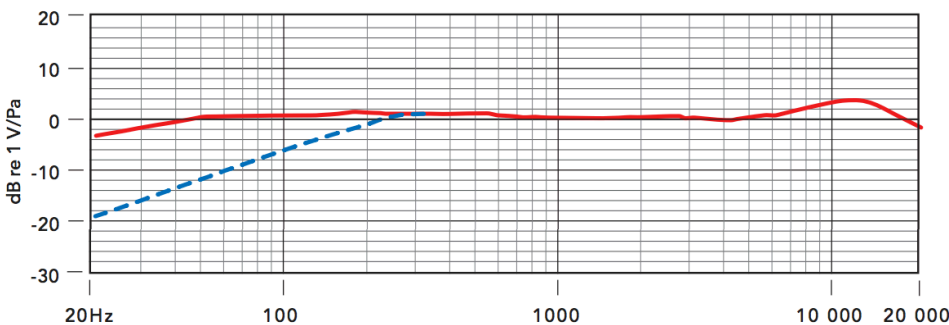
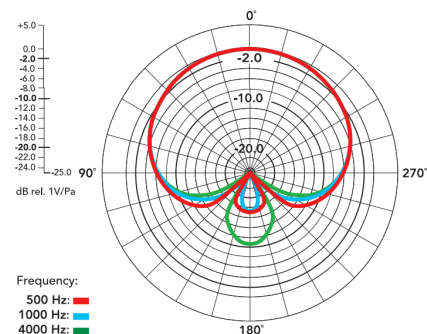
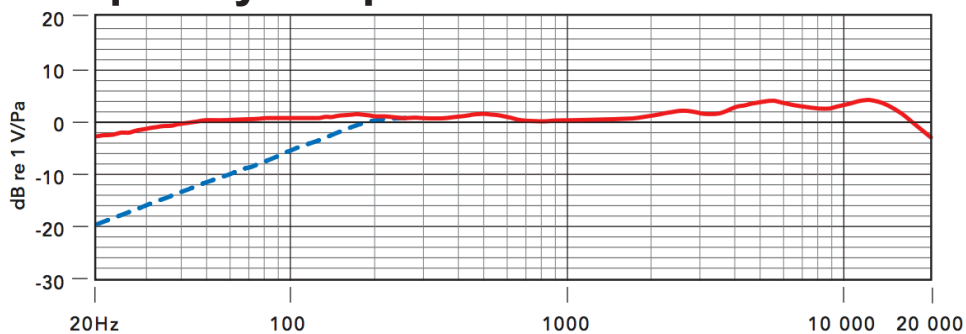

Notes:

- Known as a solid all-rounder mic, will reliably sound good on any instrument you put it in front of
- Same frequency charts as NT2-A, but in practice has a very different sound

RODE NT1



TYPE Large Diaphragm Condenser

PICKUP Cardioid

POWER 48v

COMMON USES Piano, Cymbals, VO, Foley

SIMILAR MICS MXL 770, NT2A

Frequency Response:

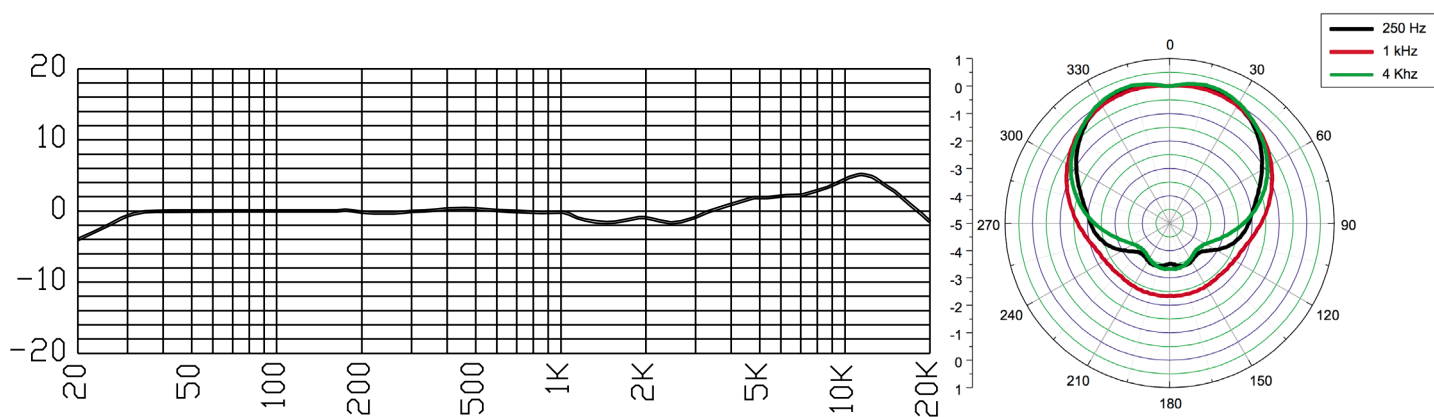

Notes:

- This is the original version of the much-revised NT1 from the 90s
- Usually described as having a “gritty” sound

RODE NT2-A



TYPE Large Diaphragm Condenser

PICKUP Cardioid, Omni, Figure 8

POWER 48v

COMMON USES VO, Piano, Drum Overhead, Acoustic Guitar

SIMILAR MICS NT2000

Frequency Response:

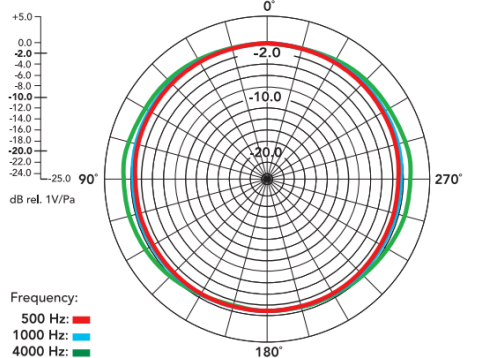
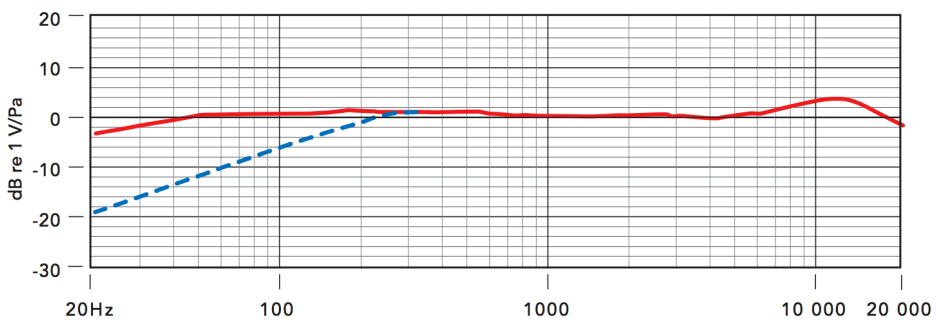
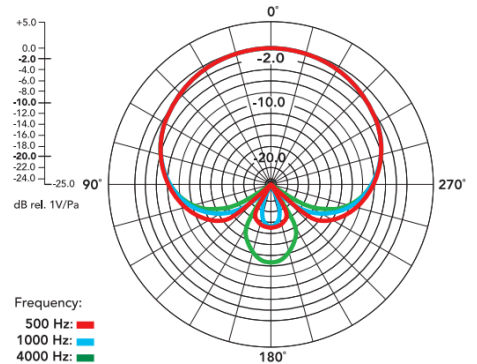
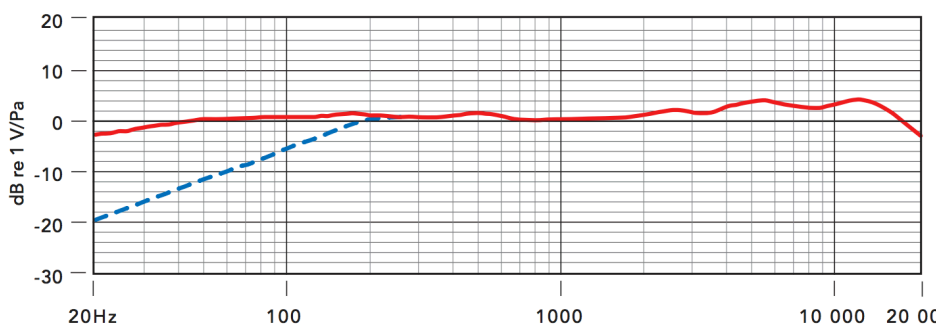

Notes:

- One of the lowest noise floors on the market
- A “gritty” sound when compared to the smooth-sounding NT2000

MINI SHOTGUN MICS

Panasonic AG MC-200



TYPE Mini Shotgun Condenser

PICKUP Supercardioid

POWER 48v (XLR Phantom Power Only)

Frequency Response:

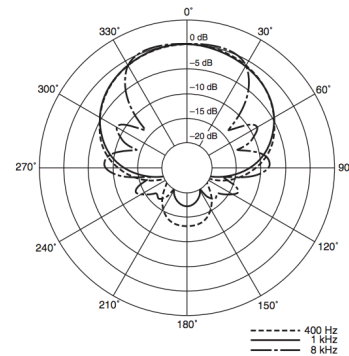
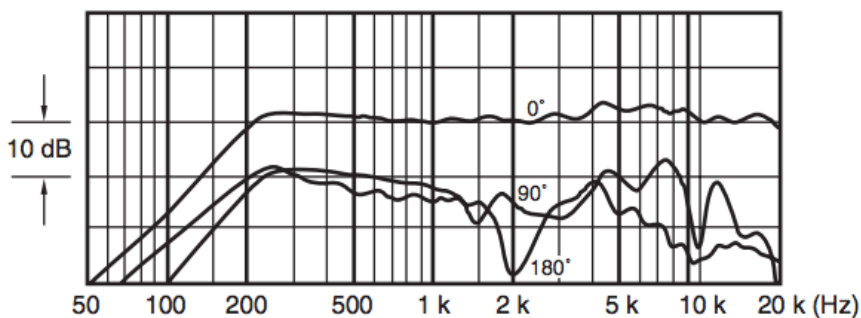

TYPE Mini Shotgun Condenser

PICKUP Supercardioid

POWER 48v (XLR Phantom Power Only)

Panasonic AG MC-100

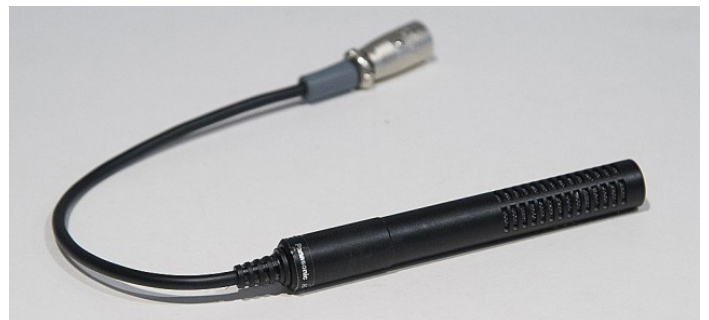

Notes:

- Neither take batteries, must be plugged into an XLR jack to receive phantom power (XLR to Mini converters will not work)
- Intended for use with Panasonic AC90 Camera

APEX 215



TYPE Dual-Ribbon

PICKUP Bidirectional

POWER NONE ****DO NOT SEND PHANTOM POWER****

COMMON USES Guitar, Strings, Pia

SIMILAR MICS Unique

Frequency Response:

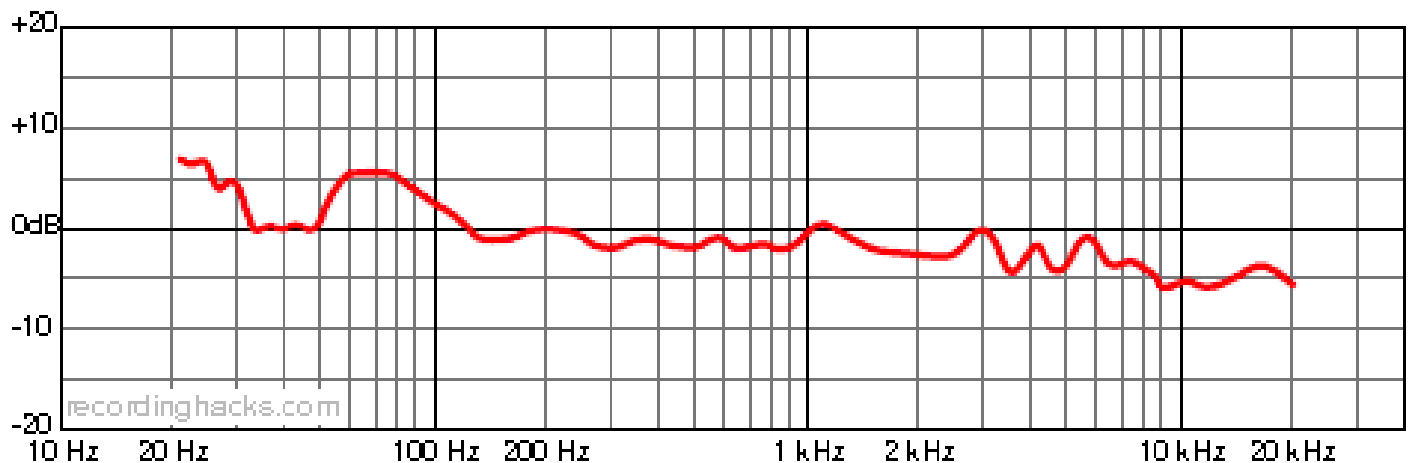

Notes:

- Dual-ribbon design makes for higher sensitivity/more detailed recordings than single-ribbon designs
- Can handle SPLs up to 137dB, so don't be afraid to use as drum overheads or amp mics
- Very warm, bass-rich sound

COLES 4038



TYPE Ribbon

PICKUP Figure 8

POWER NONE **DO NOT SEND PHANTOM POWER**

COMMON USES Mono Drum Overhead/
Room, Horns, Acc. Guitar

SIMILAR MICS Unique

Frequency Response:

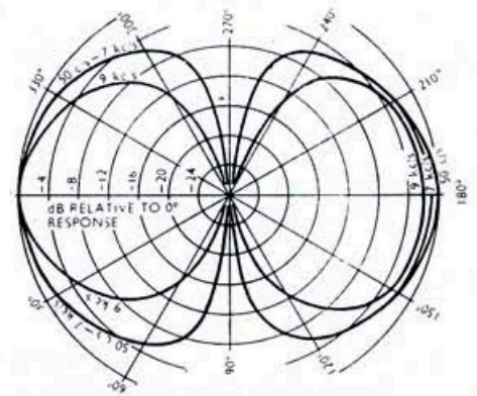
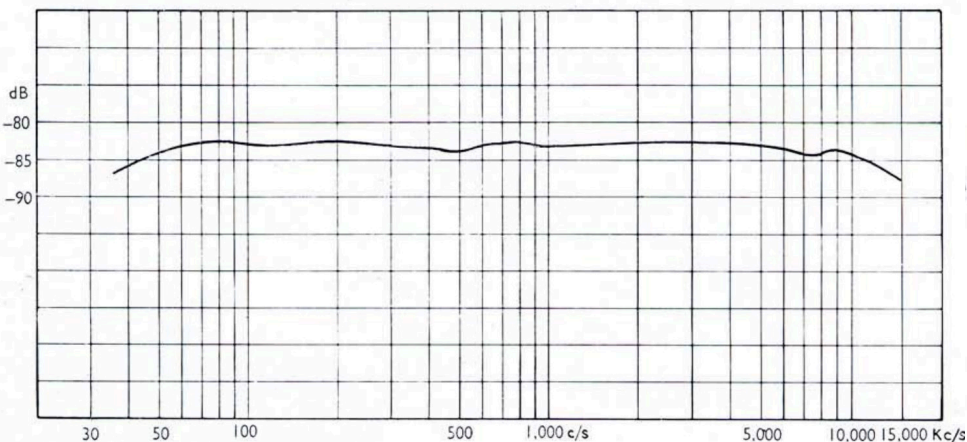

Fig. 3 VERTICAL

Notes:

- Legendary ribbon mic from the 1950s
- Considered one of the smoothest sounding mics around
- Drum overhead mic of choice for The Beatles and Led Zeppelin
- Handle with great care and caution. Use a pop filter with vocals, and keep static-resistant cover on it when not in use

SENNHEISER MD 421-II



TYPE Dynamic

PICKUP Cardioid

POWER None

COMMON USES Toms, Snare, Bass, Vocals

SIMILAR MICS PR-30

Frequency Response:

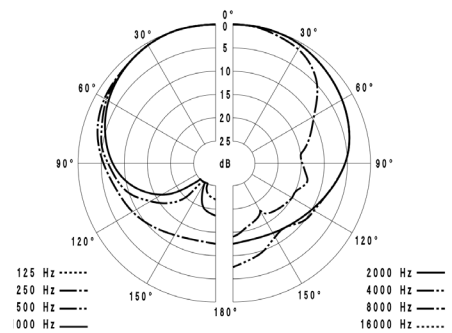
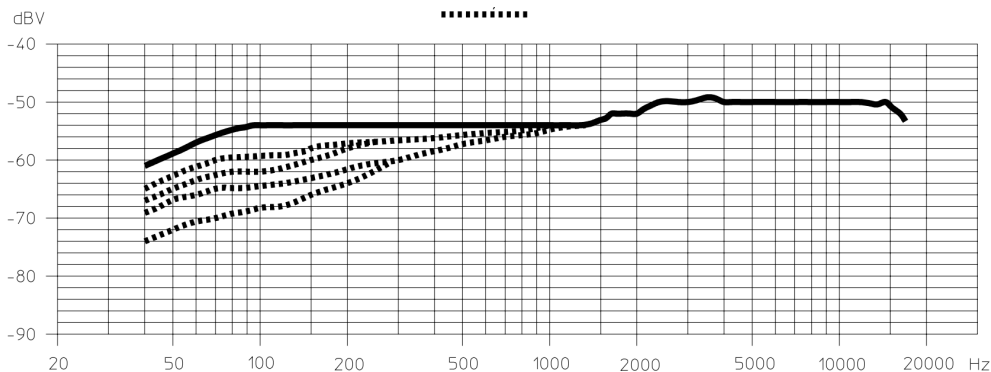

Notes:

- Dial at bottom of mic is for bass roll off, ranges from “Music” (No attenuation) to “Speech” (-6db to everything under 500hz)
- While this mic is most commonly used as a drum mic, many find that it works great with vocals, specifically loud male singers of rock, rap, metal and similar styles.

SONY C-76



TYPE Giant Shotgun Mic

PICKUP Superunidirectional

POWER 48v or 9V Battery

COMMON USES Location Sound, Jousting

SIMILAR MICS Unique

Frequency Response:

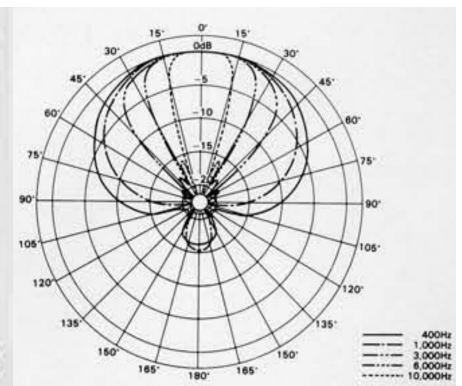
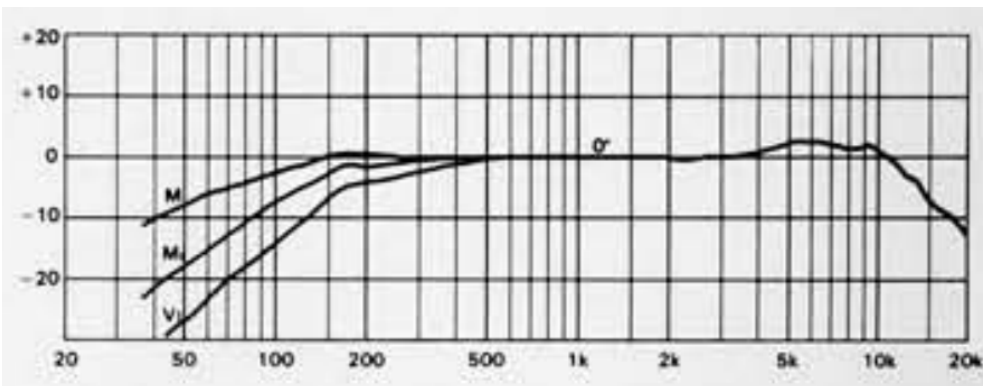

Notes:

- Over 2 feet long
- Very directional, making it very useful for capturing clear audio in noisy environments
- 3 stage of low-end roll off: M, M1, and V1

SENNHEISER MKE 600



TYPE Shotgun Condenser

PICKUP Supercardioid

POWER 48v or 1 AA Battery

COMMON USES Location Sound, Field Recording

SIMILAR MICS AT897, ME66

Frequency Response:

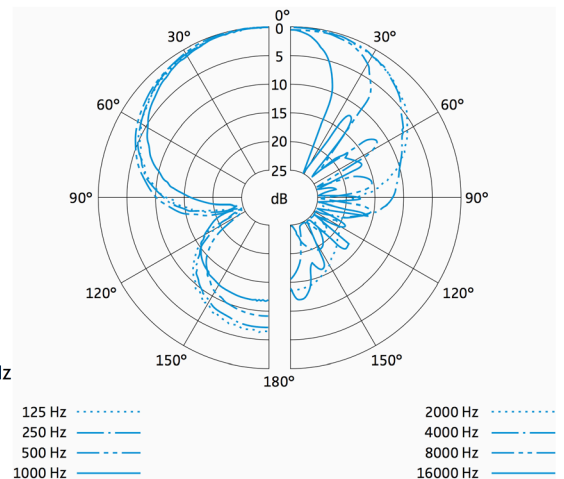
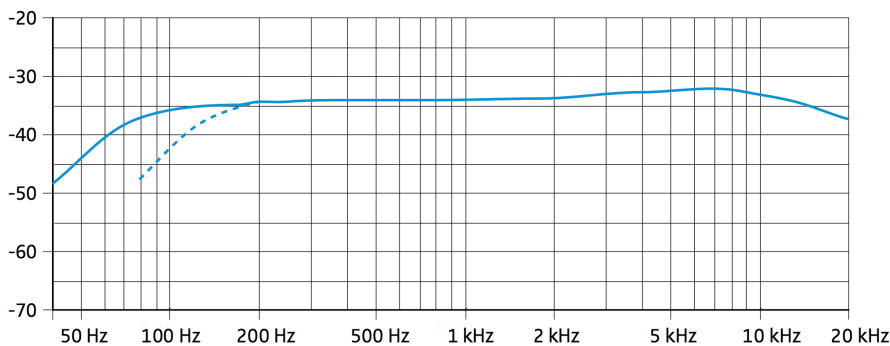

Notes:

- LED Above BATT switch only turns on when battery is low, it is not an indicator of whether or not the microphone is actually turned on
- Bass roll-off filter (150hz and below) switch to reduce handling noise

AUDIO-TECHNICA AT897



TYPE Shotgun Condenser

PICKUP Supercardioid

POWER 48v or 1 AA Battery

COMMON USES Location Sound, Field Recording

SIMILAR MICS MKE600, ME66

Frequency Response:

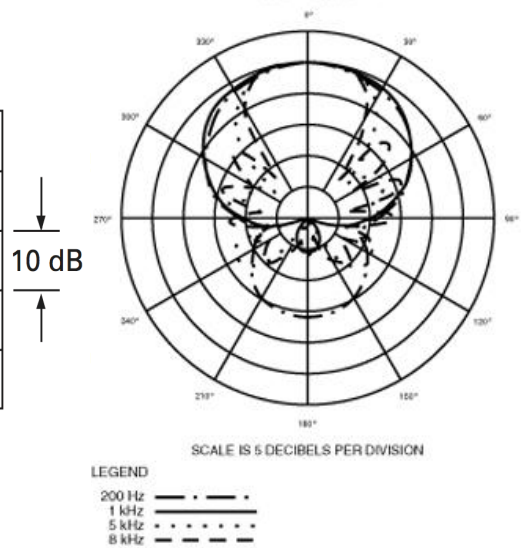
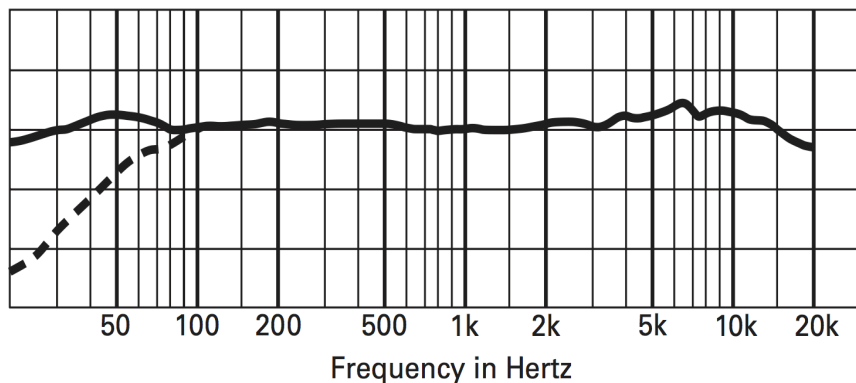

Notes:

- Bass roll-off filter switch (80hz and below) to reduce handling noise. Use a pin or thin screwdriver to engage
- Unscrew bottom half of microphone to insert battery

SENNHEISER ME66



TYPE Shotgun Condenser

PICKUP Supercardioid

POWER 48v or 1 AA Battery

COMMON USES Location Sound, Field Recording

SIMILAR MICS AT897, MKE 600

Frequency Response:

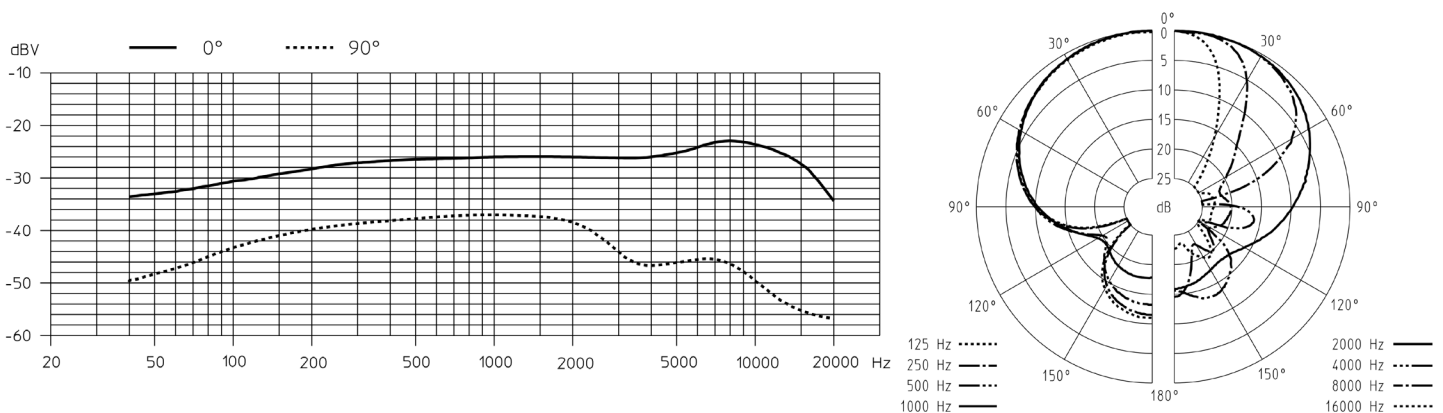

Notes:

- High 125 dB maximum SPL provides distortion-free recording
- Switchable bass roll-off filter (400hz and below), use a pin or thin screwdriver to engage
- LED Above BATT switch only turns on when battery is low, it is not an indicator of whether or not the microphone is actually turned on

RODE NTG2



TYPE Shotgun Condenser

PICKUP Supercardioid

POWER 48v or 1 AA Battery

COMMON USES Location Sound, Field Recording

SIMILAR MICS MKE 600, ME66

Frequency Response:

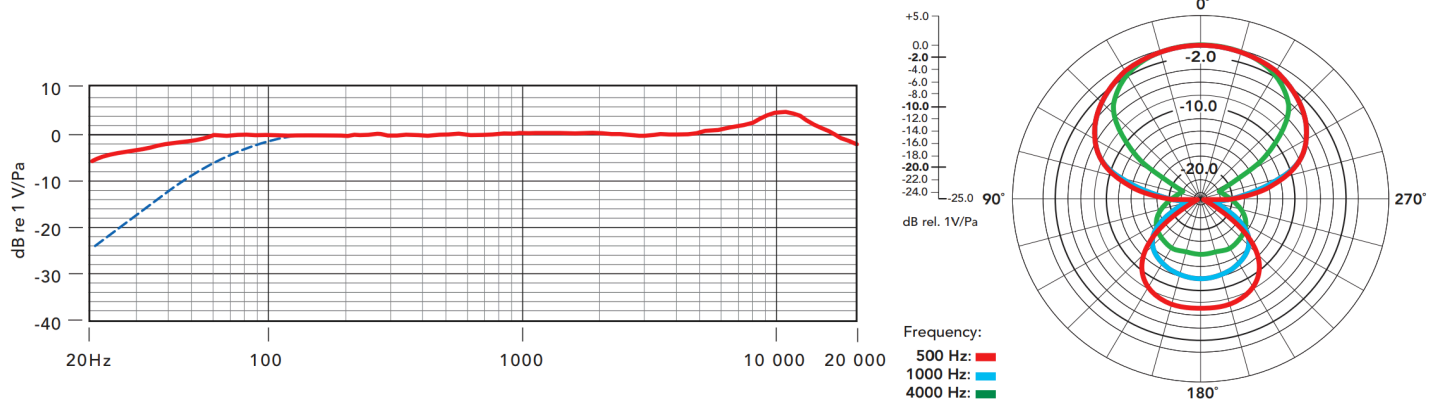

Notes:

- Great for indoor use, effectively eliminates room characteristics for an isolated sound
- Switchable bass roll-off filter (80hz and below), use a pin or thin screwdriver to engage

SHURE VP83F LENSHOPPER



TYPE Camera-mounted Shotgun Condenser

PICKUP Supercardioid

POWER 2x AA Batteries

COMMON USES DSLR Audio

SIMILAR MICS VideoMic Pro

Frequency Response:

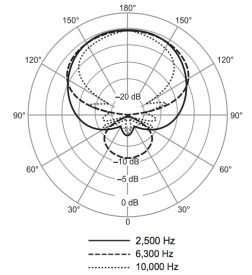
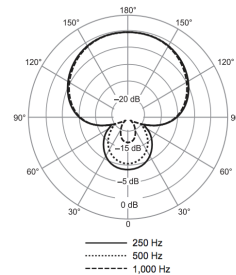
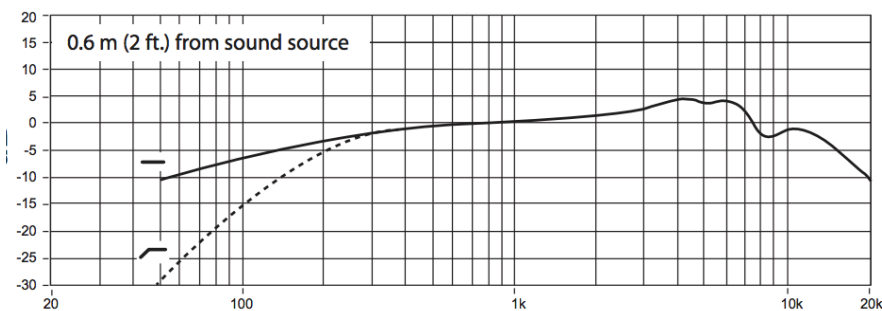

Notes:

- A DSLR-mountable microphone with a built-in recorder
- Comes with MicroSD card
- Mini-to-mini connectivity available for output to camera
- Press record button to record. Press again to pause. Hold down record button for 2 seconds to stop.
- Solid red LED means recording, flashing LED means paused

RODE VIDEOMIC PRO



TYPE Camera-mounted Shotgun Condenser

PICKUP Supercardioid

POWER 1x 9V Battery

COMMON USES DSLR Audio

SIMILAR MICS VP83F

Frequency Response:

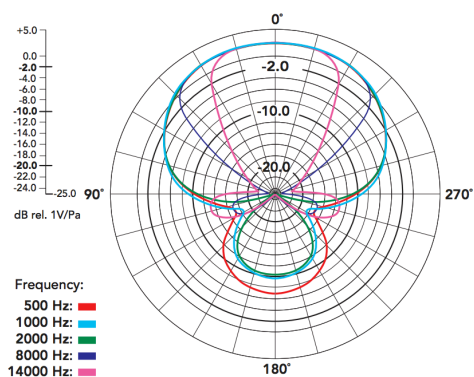
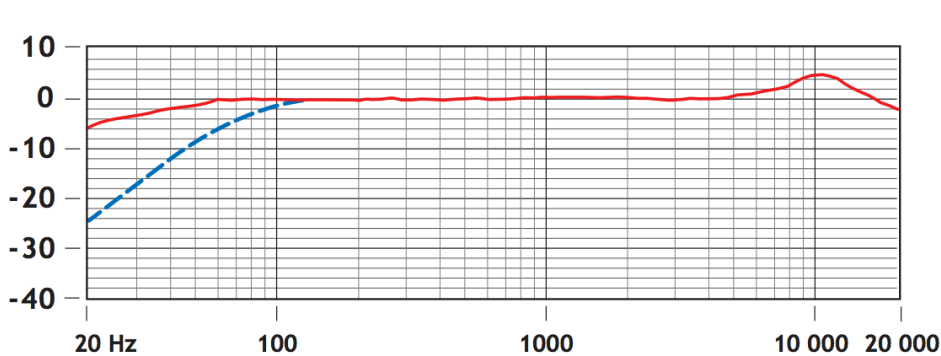

Notes:

- Power switch engages bass cut when pushed all the way to the right
- “dB” switch either pads the signal by 10db or boosts it by 20db
- 3.5mm mini output

APEX 170



TYPE	Small Diaphragm Pencil Condenser
-------------	---

PICKUP	Cardioid
---------------	-----------------

POWER	48v or Battery
--------------	-----------------------

COMMON USES	Live Drums, Strings, Brass
--------------------	-----------------------------------

SIMILAR MICS	
---------------------	--

Notes:

- Condenser with a tight pickup pattern and good off-axis sound rejection
- Frequency range from 80hz to 15khz
- Mysterious. Not a lot of information online. Try it and see

AUDIO TECHNICA AT8022



TYPE Stereo Small Diaphragm Condenser

PICKUP X/Y Stereo Cardioid

POWER 48v or Battery

COMMON USES Field Recording

SIMILAR MICS NT4, S502

Frequency Response:

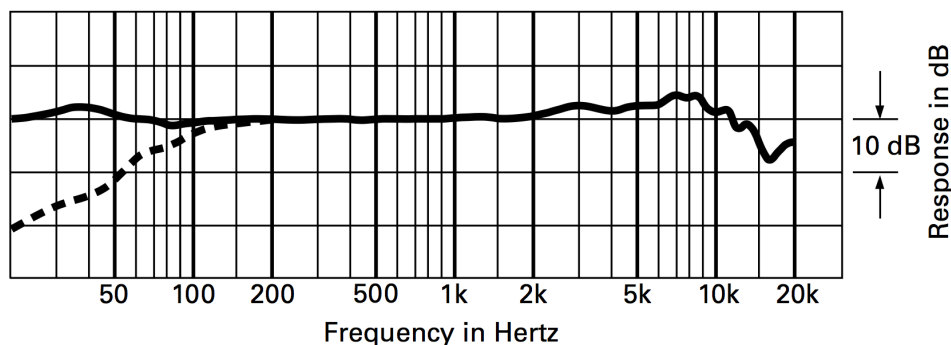

polar pattern (200 Hz)

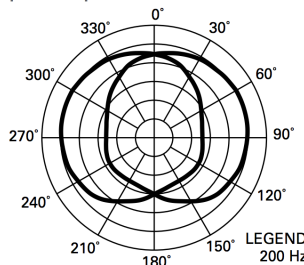

polar pattern (1 kHz)

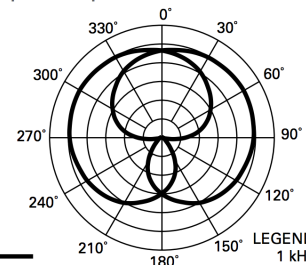

polar pattern (8 kHz)

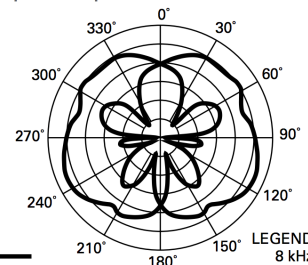

Notes:

- **Top-Address**
- Ideal for mounting on top of cameras for quick and easy stereo sound

EARTHWORKS SR30 PAIR



TYPE Small Diaphragm Condenser

PICKUP Cardioid

POWER 48V

COMMON USES Drum Overheads, Piano, Sound Design, Foley

SIMILAR MICS NT5

Frequency Response:

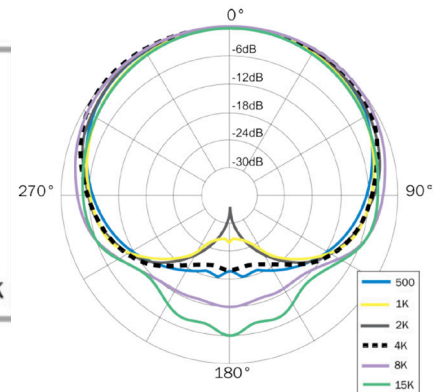
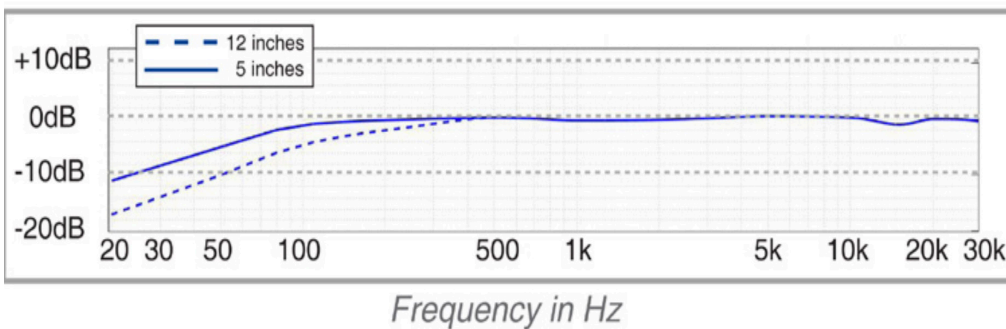

Notes:

- Extended Frequency Range (5hz-30khz)
- Because of its very flat frequency response and near perfect cardioid pickup pattern, the SR30 captures an incredibly “objective” sound

RODE NT4



TYPE Stereo Small Diaphragm Condenser

PICKUP X/Y Stereo Cardioid

POWER 48v or 9V Battery

COMMON USES Drum Overhead, Piano, SFX, Field Recording

SIMILAR MICS NT5

Frequency Response:

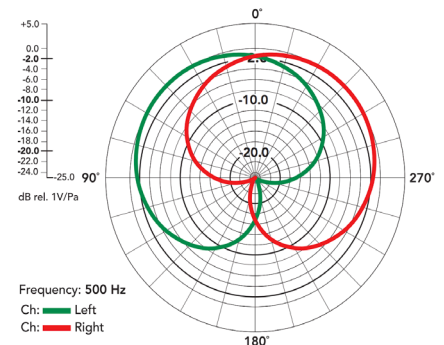
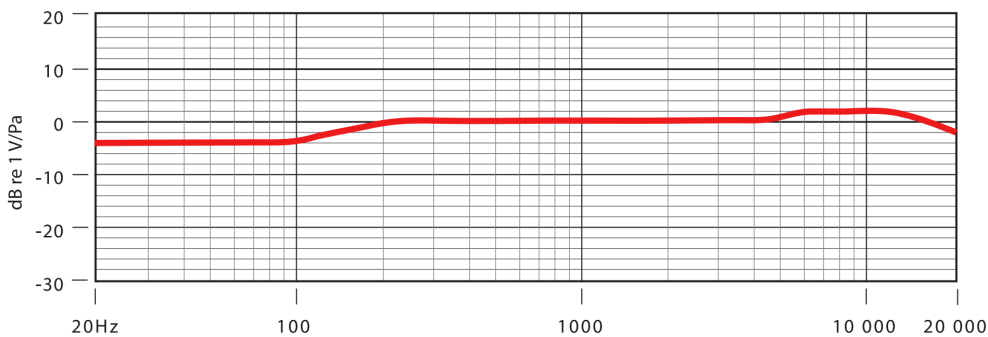

Notes:

- Uses the same mic capsules as the NT4, but fixed at a perfect XY alignment
- Custom 5-pin XLR to dual 3-pin XLR output
- Switch on top controls whether it is powered by phantom power or battery

RODE NT5



TYPE Small Diaphragm Pencil Condenser Pair

PICKUP Cardioid

POWER 48v

COMMON USES Drum Overhead, Acoustic Gtr, Indoor Dialogue, Strings

SIMILAR MICS NT4

Frequency Response:

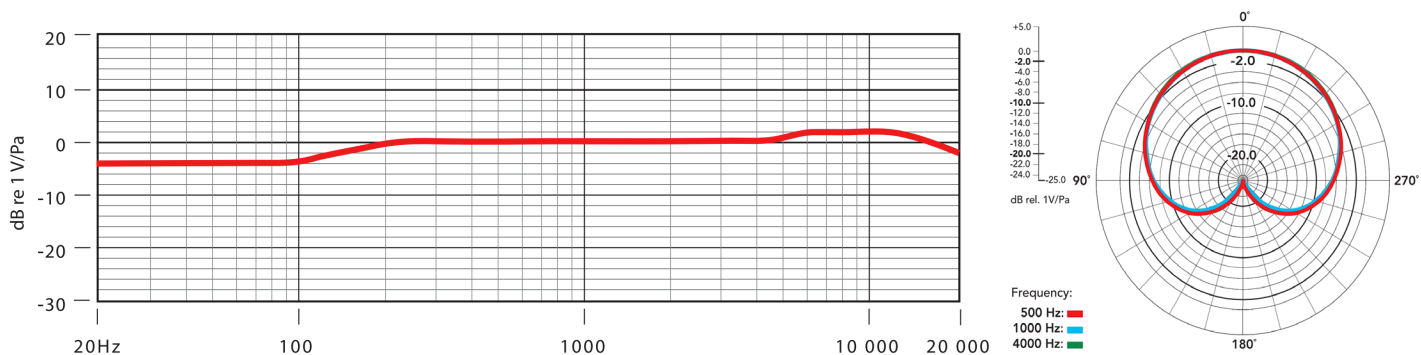

Notes:

- Uses the same mic capsules as the NT4
- Bootsy Collins's favourite mic for acoustic guitar, strings, and room
- Comes as a matched pair, but are excellent for individual use as well

SCHEOPS CMC5-U w/ MK 4 CAPSULE



TYPE Small Diaphragm Pencil Condenser

PICKUP Cardioid

POWER 48v

COMMON USES Cymbals, Strings, Woodwinds, Foley

SIMILAR MICS NT5

Frequency Response:

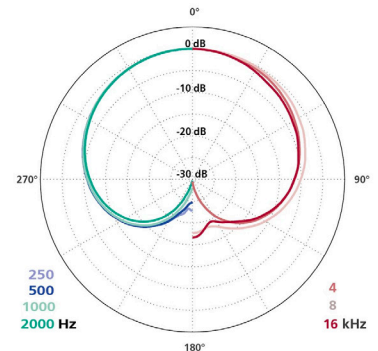
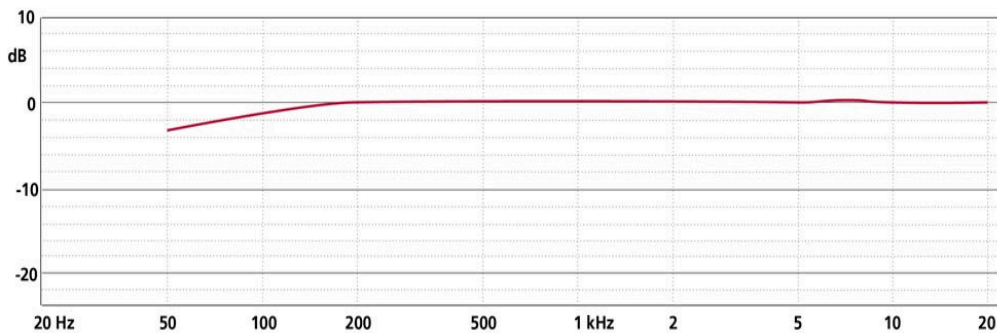

Notes:

- The CMC5U is a microphone body/amplifier that has a unique “modular” design that allows you to swap out different capsules for different purposes and sounds
- The MK 4 capsule is used for a totally flat, transparent sound - a perfect jumping-off point for EQ and “colouring” the signal.
- The Berlin Philharmonic Concert Hall uses this as their mic of choice for opera vocalists

SUPERLUX S502



TYPE Stereo Small Diaphragm Condenser

PICKUP Fixed ORTF/Cardioid

POWER 48v

COMMON USES Choir, Orchestra, Field Recording, Drum Room

SIMILAR MICS Unique

Frequency Response:

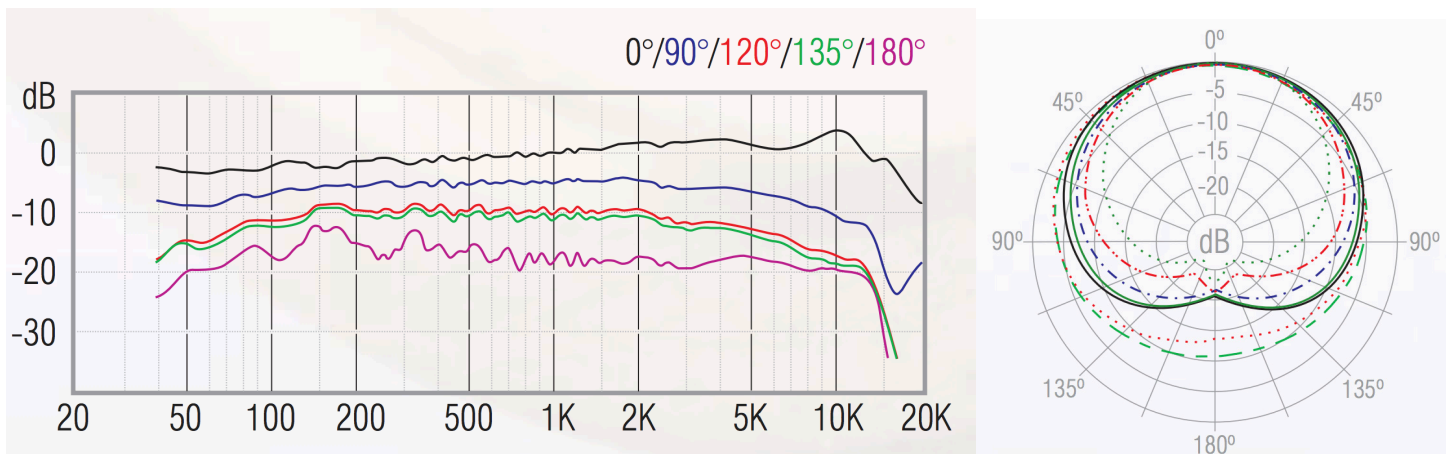

Notes:

- ORTF positioning technique closely reproduces the pickup of human hearing
- Comes with 5-pin XLR splitter, requires 2 input channels for stereo recording
- Should be placed at least 1 meter from sound source for best results

BLUE SNOWBALL



TYPE USB Condenser Mic

PICKUP Cardioid, Omnidirectional

POWER USB

COMMON USES Voiceover, Podcast, Livestream

SIMILAR MICS Blue Nessie

Frequency Response:

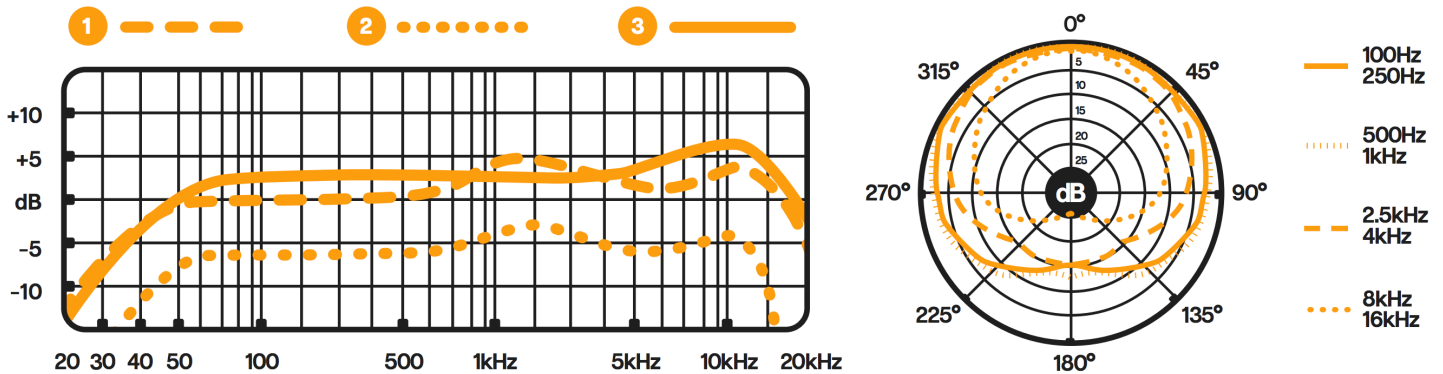

Notes:

- Simple plug n' play design. No drivers or setup required
- Features a -10db pad switch for capturing loud sound sources without distortion
- Switch on the back changes pickup patterns from "1" (Cardioid), "2" (Omnidirectional), and "3" (Cardioid with -10db pad)

BLUE NESSIE



TYPE	USB Condenser Mic
-------------	--------------------------

PICKUP	Cardioid
---------------	-----------------

POWER	USB
--------------	------------

COMMON USES	Voiceover, Podcast, Home Music Recording
--------------------	---

SIMILAR MICS	Blue Snowball
---------------------	----------------------

Notes:

- “The only mic with a built-in sound engineer”
- Adaptive EQ, de-esser, and levelling automatically smooths audio in real time
- Built-in shock mount and pop filter keeps rumbles and pops to a minimum without any extra accessories
- 3 different modes, “Vocal”, “Music”, and “Raw”
- Plug n’ play, no drivers or setup required
- Rotating base controls volume level, red button is an instant mute, and headphone port is located on the back

SONY ECM-44B



TYPE Wired Condenser Lav

PICKUP Omnidirectional

POWER 1x AA Battery

COMMON USES Live Studio Interview

SIMILAR MICS ECM-55B

Frequency Response:

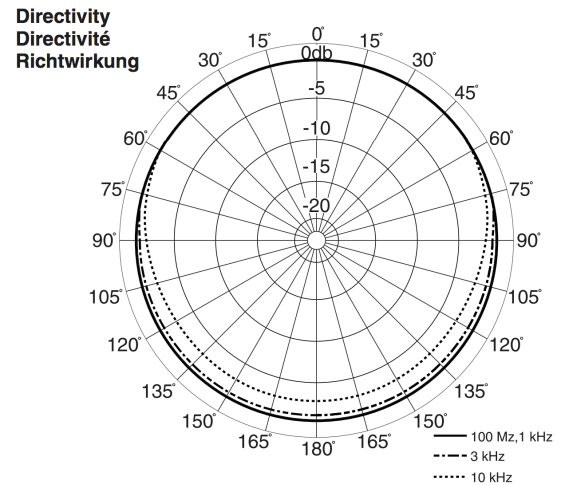
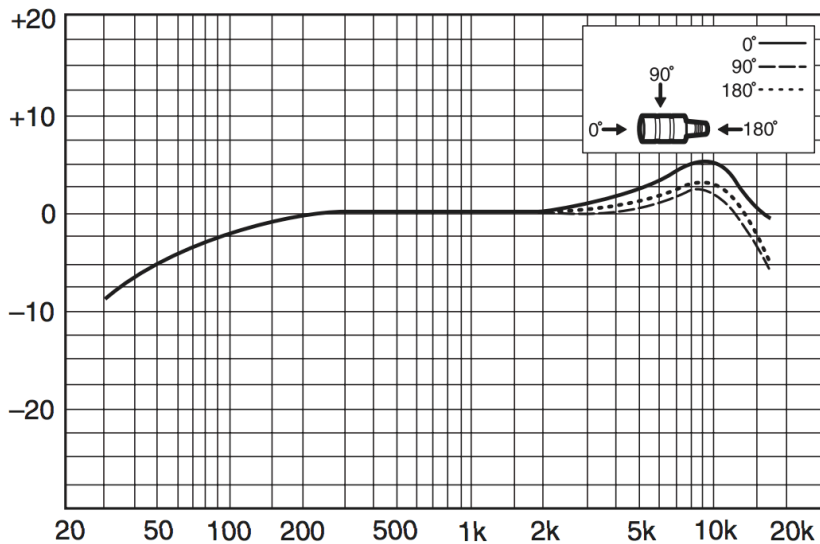

Notes:

- Does NOT take phantom power, must be powered by an internal battery
- Better suited for live and interview application than EFP purposes due to limited frequency response

COUNTRYMAN B3



TYPE Wired Condenser Lav

PICKUP Omnidirectional

POWER 48v

COMMON USES Dialogue, Voiceover, Studio or Documentary Interview

SIMILAR MICS AT899

Frequency Response:

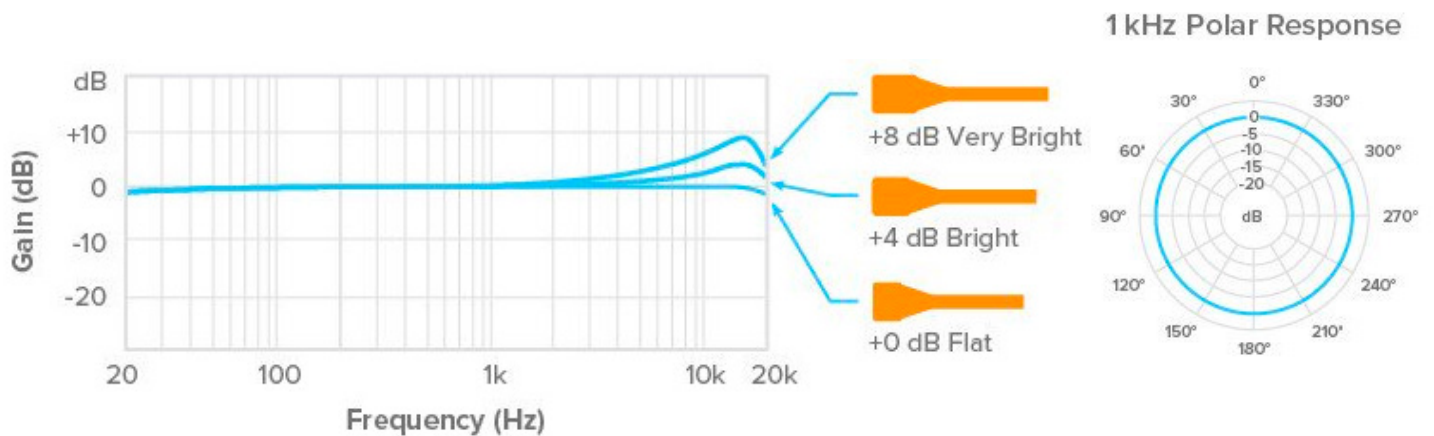

Notes:

- Full spectrum frequency response and ability to handle up to 140 dBA SPL without distortion makes it suitable in any voice recording context

SONY ECM-55B



TYPE Wired Condenser Lav

PICKUP Omnidirectional

POWER 48v or 1x AA Battery

COMMON USES Studio/Documentary Interview, Dialogue

SIMILAR MICS ECM-44B

Frequency Response:

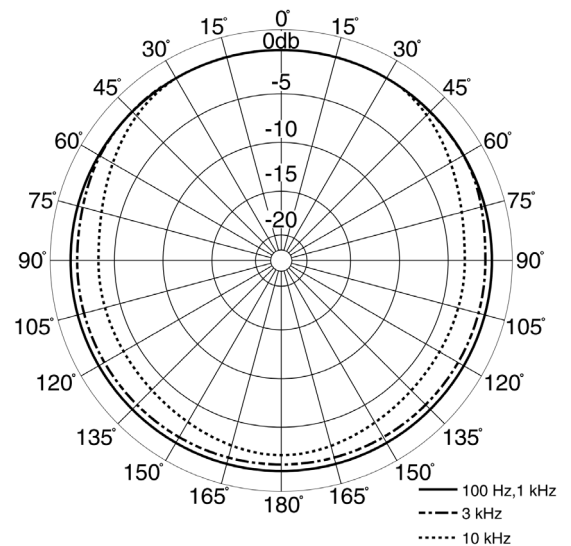
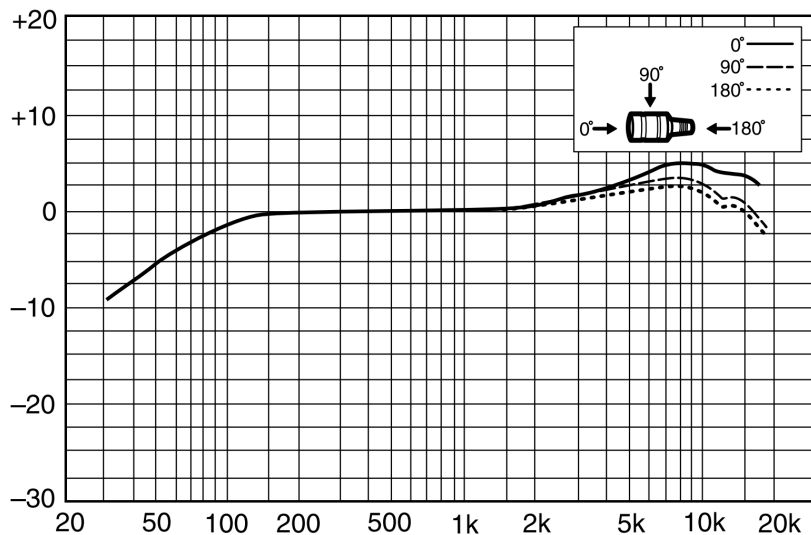

Notes:

- Manufacturer's suggestion: Turn on 10 minutes before use to ensure the most stable performance
- Larger mic head (10mm diameter) provides rich sound reproduction

AUDIO-TECHNICA AT899



TYPE	Wired Condenser Lav
PICKUP	Omnidirectional
POWER	48v or 1x AA Battery
COMMON USES	Dialogue, Voiceover, Studio or Documentary Interview
SIMILAR MICS	Countryman B3

Frequency Response:

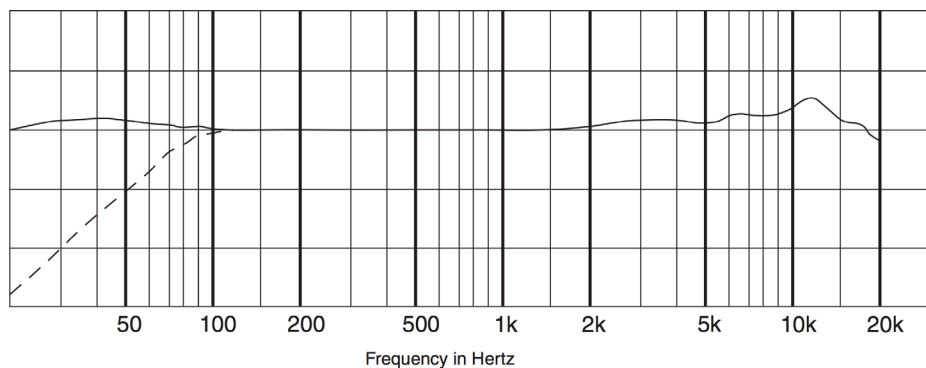

LEGEND ——— 12" or more on axis
 - - - - - Roll-off

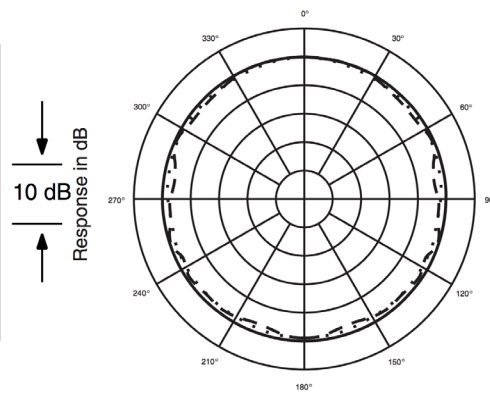

LEGEND
 200 Hz ——— same as 1 kHz
 1 kHz - - - - -
 5 kHz
 8 kHz - - - - -

Notes:

- Very discrete, 5mm in diameter
- Low-frequency roll-off switch for reducing pops and rumble
- Great bass response for capturing full-bodied sound

SENNHEISER EW100 G3 w/ ME 2 MIC



TYPE Wireless Lavalier

PICKUP Omnidirectional

POWER 4x AA Batteries

COMMON USES Dialogue, Field Production, Interview

SIMILAR MICS None

Notes:

- Includes lav mic with one wireless transmitter and one receiver
- To find a frequency without any interference: Open the menu on the receiver, go to “Easy Setup” and “Scan New List”
- To easily pair the transmitter with the receiver: Open the menu on the receiver, go to “Sync”, open the hatches on both packs and hold them face-to-face, about 6 inches from each other
- Receiver pack can be used in combination with the XLR Mic Transmitter to make any mic wireless

