

33-BUS TEST SYSTEM

This document contains information for the modified 33-bus test system shown in Fig. 1. The modified 33-bus test system is an adaptation from the IEEE 33-bus test system with the following characteristics:

- The nominal voltage is set at 13.8 kV at the substation.
- The substation transformer at bus 1 has a capacity of 3 MW.
- Composed of seven Zones.
- The nominal demand is shown in Table I for all buses and the loading factors for the considered three time segmentation are 80%, 60%, and 100% of the nominal value, respectively.
- Data of existing and new distribution branches are provided in Tables II and III respectively.

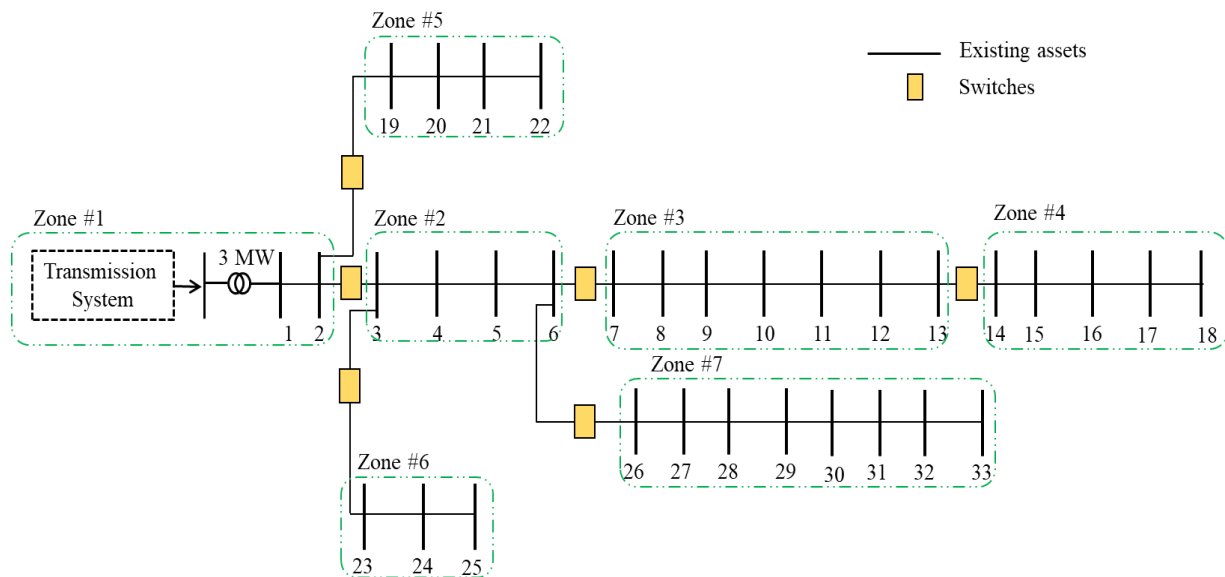

Fig. 1 Illustrative 33-bus test system.

TABLE I ZONAL LOADING SUMMARY OF THE 33-BUS TEST SYSTEM

Zone	1	2	3	4	5	6	7	Total
Nominal Load (kW)	100	330	685	390	360	930	920	3,715

TABLE II DATA OF EXISTING DISTRIBUTION BRANCHES OF THE 33-BUS TEST SYSTEM

From	To	R (Ω)	X (Ω)	Current Capacity (Amp)
1	2	0.0922	0.0477	500
2	3	0.493	0.2511	500
3	4	0.366	0.1864	500
4	5	0.3811	0.1941	500
5	6	0.819	0.707	500
6	7	0.1872	0.6188	500
7	8	1.7114	1.2351	500
8	9	1.03	0.74	500
9	10	1.04	0.74	500
10	11	0.1966	0.065	500
11	12	0.3744	0.1238	500
12	13	1.468	1.155	500
13	14	0.5416	0.7129	500
14	15	0.591	0.526	500
15	16	0.7463	0.545	500
16	17	1.289	1.721	500
17	18	0.732	0.574	500
2	19	0.164	0.1565	500
19	20	1.5042	1.3554	500
20	21	0.4095	0.4784	500
21	22	0.7089	0.9373	500
3	23	0.4512	0.3083	500
23	24	0.898	0.7091	500
24	25	0.896	0.7011	500
6	26	0.203	0.1034	500
26	27	0.2842	0.1447	500
27	28	1.059	0.9337	500
28	29	0.8042	0.7006	500
29	30	0.5075	0.2585	500
30	31	0.9744	0.963	500
31	32	0.3105	0.3619	500
32	33	0.341	0.5302	500

TABLE III DATA OF NEW DISTRIBUTION BRANCHES OF THE 33-BUS TEST SYSTEM

From	To	R (Ω)	X (Ω)	Length (km)	Current Capacity (Amp)
22	12	0.0922	0.0477	5	500
25	29	0.493	0.2511	3.57	500
9	15	0.366	0.1864	8	500

Further, Table IV shows the summary of network upgrading options, while Fig. 2 illustrates the location of the assets in the system. The power capacity transactions bids from transmission system and DERs are provided in Table V.

TABLE IV Bid for Asset Upgrades

Description	Lifetime (year)	Rating (kVA)	Cost (k\$/year)
Substation Transformer	20	1,000	600
Substation Transformer	20	2,000	1000
Description	Lifetime (year)	Length (km)	Cost (k\$/year)
Distribution Branch	20	1	35

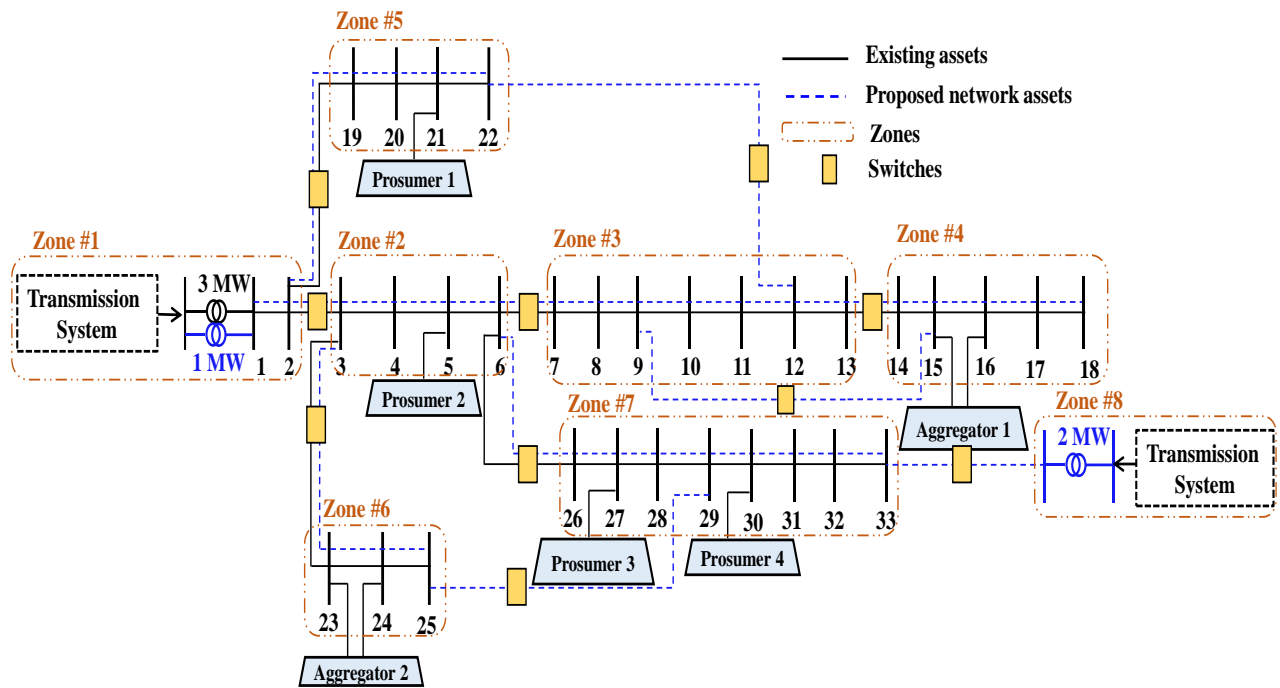

Fig. 2 Illustrative 33-bus test system including all planning options.

TABLE V BIDS OF POWER CAPACITY TRANSACTIONS FROM TS AND DERs

Participant (Technology)	Location (node #)	Max Power (MW)	Price \$/MW- day	# of bid segments	Power capacity (MW) for each time segment		
					#1	#2	#3
Transmission	1	-	150	6	0.5	0.5	0.5
Transmission	33	-	150	4	0.5	0.5	0.5
Aggregator 1 (Wind & ES)	15 & 16	1	300	2	-	-	0.5
Aggregator 2 (Diesel)	23 & 24	0.5	200	1	0.5	0.5	0.5
Prosumer 1 (PV & ES)	21	0.5	225	1	-	0.5	-
Prosumer 2 (EV)	5	0.2	380	1	0.2	-	-
Prosumer 3 (Wind & ES)	27	1	250	2	-	-	0.5
Prosumer 4 (CHP)	30	1.5	220	3	0.5	0.5	0.5